

SMA PUSH-ON

1. SMA Specifications/Interface Dimensions	108
2. Connectors of Type SMA PUSH-ON	111
3. Adapters to SMA PUSH-ON	115

CONTENT
INTRODUCTION to PUSH-ON CONNECTORS & ADAPTERS Page 9
7/16 PUSH-ON Page 15
BMA Page 27
N PUSH-ON Page 45
SBX Page 61
SBY Page 85
SMA PUSH-ON
SMA Reverse Sex PUSH-ON Page 119
SMP Page 131
TNC PUSH-ON Page 193
CABLE ASSEMBLIES
with INTERCHANGEABLE CONNECTORS Page 213
Kits with I./CONNECTORS Page 221
w/ PUSH-ONs Page 225
RAW CABLE SPECIFICATIONS Page 245
RF MULTI PIN Page 265
TOOLS Page 271
ASSEMBLY INSTRUCTIONS Page 289
SPECIAL PRODUCTS & SERVICES Page 353
APPENDIX

e:/quicke98/sma-push.ppt6

PUSH-ON SMA-TYPE CONNECTORS eliminate time consuming tightening, torquing and loosening of SMA-male connectors during testing or in applications where limited space requirements make tightening and torquing of a coupling nut difficult, if not impossible.

The SMA push-on slides directly onto any standard SMA-female, allowing prompt connection and loosening. Three types of push-on SMA connectors are available: full-locking, locking with non-locking rear nut, and non-locking.

Full Locking push-on SMA-Type connectors are recommended when longer testing is required and the connectors must be firmly locked so that they cannot be disconnected, even by mistake. **Locking with non-locking rear nut** SMA-Type connectors are recommended where safe locking is necessary, but long term testing is not required. **Non-locking** push-on connectors are recommended for short period testing, testing that usually takes only seconds.

Push-On SMA-Type connectors are available for termination with cables RG-142B/U, RG-400/U and RG-214/U. State-of-the-art high performance cables using push-on connectors are available as well, however, these high performance cable assemblies are only available completely terminated; they can be found in the section "Cable Assemblies" on pages 234-236 of this catalog.

PUSH-ON SMA-TYPE CONNECTOR SAVERS, or adapters, were developed for attachment to cable assemblies which are terminated with regular connectors. The adapter has a standard connector on one side, and a push-on connector on the other end. The standard connector end of the adapter engages with the standard connector of the opposite sex at the cable assembly. These connector savers modify cable assemblies in seconds, changing them from a standard product to a state-of-the-art push-on assembly.

Push-on adapters are available for a variety of connectors and both male and female sexes within the connector series. SMA-type push-on connectors savers are supplied in **locking with non-locking rear nut** and **non-locking** configuration.

FEATURES:

REPEATABLE PERFORMANCE
SAFE LOCKING MECHANISM*
REDUCED TEST TIME

* on Full Locking and Locking Units

LOW INSERTION LOSS
HIGH RETURN LOSS
DC- 26.5 GHz
LONG LIFE

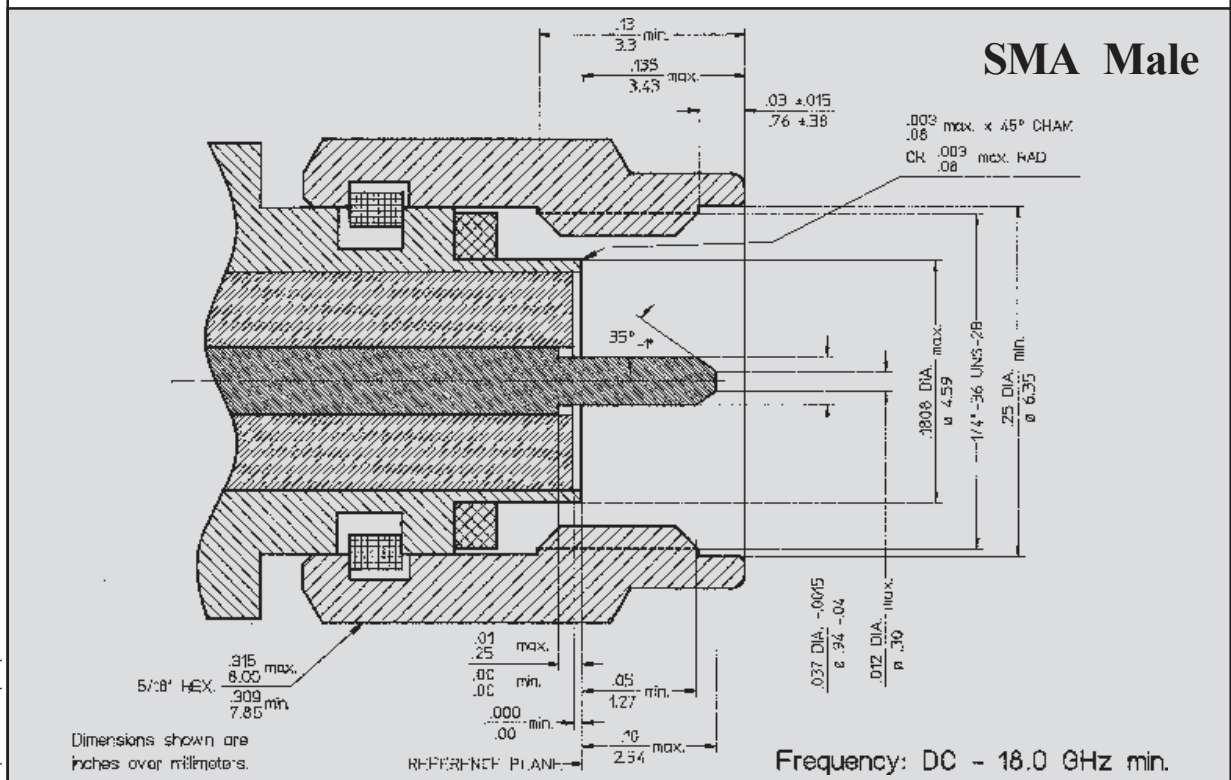
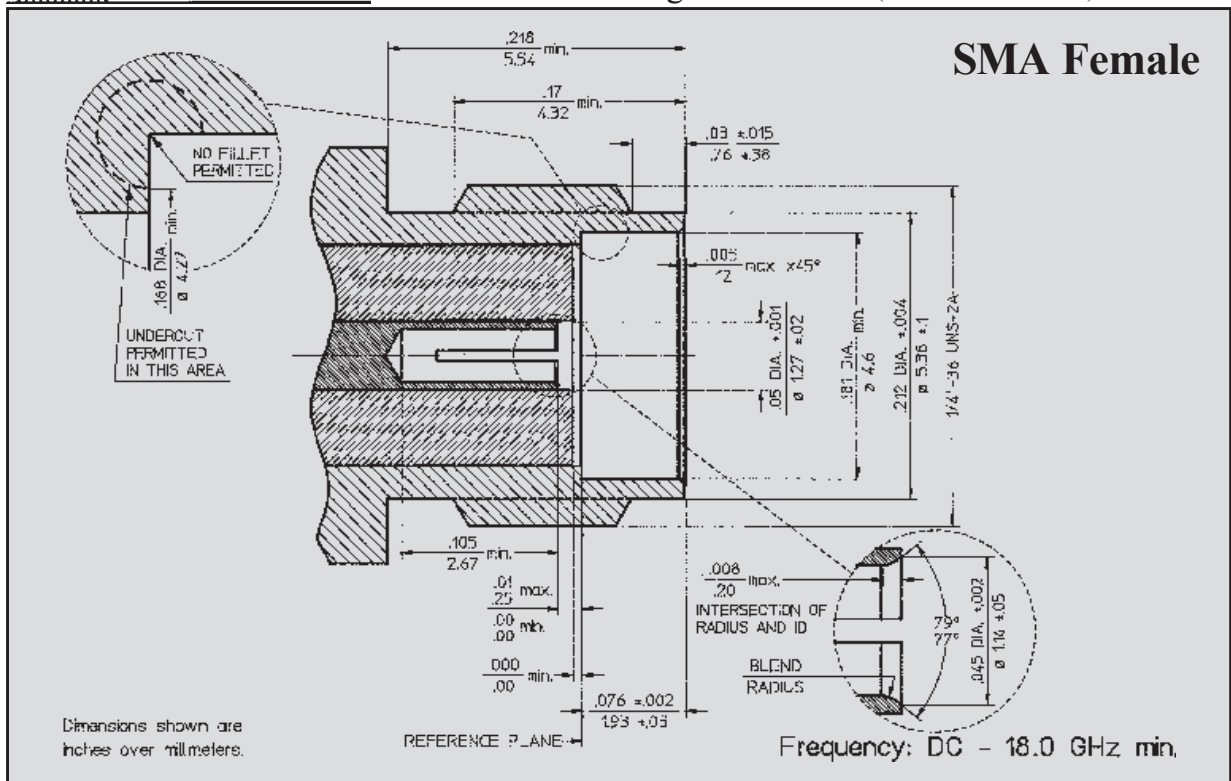

e:\quicke98\sma-push.prm6

SMA PUSH-ON Specifications to MIL-C-39012



The specifications below are general specifications for all SMA PUSH-ON connectors. Specifications in the following table are recommended for any procurement documents or drawings. In the event of any conflict, these specifications shall govern. The PUSH-ON Connectors were developed to eliminate the time consuming lightening, torquing and loosening of connectors during test. The connector slides directly onto any Female of the same connector style, allowing quick connecting and disconnecting. Its mechanism locks safely onto the standard thread of the Female connector.

REQUIREMENT	REQUIREMENT PARAGRAPH	GENERAL SPECIFICATIONS
GENERAL		
Standard Materials	3.3	STEEL corrosion resistant 1.4305 per DIN 17440 (QQ-S-764, class 303 or ASTM-A-582-80). ALUMINUM AlMg4.5Mn per DIN 1725, AlMgSi0.5 per DIN 1725, AlMgSi1 per DIN 1725 (6061-T6 per QQ-A-225/8). BRASS CuZn39Pb3 per DIN 17660 (QQ-B-626, halfhard). COPPER BERYLLIUM 33-25 CuBe2Pb H per DIN 17666 (QQ-C-530). TFE Fluorocarbon per DIN 52900 (MIL-P-19468 and L-P403). SILICONE RUBBER per DIN 3771 (MIL-R-5847 and ZZ-R-765, Class II B,) Grade 50 - 75. BORRIUM NITRITE Dielectric for high power applications per inhouse specification.
Finish for	COPPER BERYLLIUM 3.3.1	Center Contacts shall be gold plated to a minimum thickness of .00005 inch (1.27 µm) in accordance with MIL-G-45204, Type II, Grade C. Outer conductors shall be gold plated to a thickness of .00003 inch (0.8 µm) per MIL-G-45204, Type II, Grade C, or silver plated to a thickness of .0001 inch (2.5 µm) per QQ-S-365.
	STAINLESS STEEL	Shall be passivated per QQ-P-35 or gold plated to a thickness of .00003 inch (0.8 µm) per MIL-G-45204, Type II, Grade C.
	ALUMINUM	Conductive Parts shall have an iridited finish per MIL-C-5541.
	BRASS	Other parts, such as Coupling Nuts and Back-Bodies shall be anodized per MIL-A-8625.
	VARIOUS	Gold plated to a thickness of .00003 inch (0.8 µm) min. per MIL-45204, Type II, Grade C, or nicle plated to a thickness of .0002 inch (5µm) per QQ-N-290, grade E, or silver plated to a thickness of .0001 inch (2.5 µm) per QQ-S-365.
Design	3.4	Imoloy .0001 inch (2.5 µm) min. plating, consisting of 55% Copper / 20% Zinc / 25% Tin (on special request). The design shall be such that the outline dimensions in this catalog are met. In addition, the assembled connector shall meet the interface dimensions.
ELECTRICAL		
Frequency Range		DC - 26.5 GHz min.
Insulation Resistance	3.11	The insulation resistance shall not be less than 5.000 megohms.
Voltage Standing Wave Ratio (VSWR)	3.14	1.15 : 1 (DC - 18.0 GHz), 1.20 : 1 (18.0 - 26.5 GHz).
Contact Resistance	3.16	The center contact resistance drop shall not exceed 3.0 milliohms max.
Dielectric Withstanding Voltage	3.17	The magnitude of the test voltage shall be 1500 volts rms at 60 Hz.
RF High Potential Withstanding Voltage	3.23	The RF high potential withstanding voltage is 1,000 volts rms at 5 MHz.
RF Leakage	3.26	-80 dB max. to 3.0 GHz, -65 dB max. to 26.5 GHz
Insertion Loss	3.27	0.3 dB max. at 18.0 GHz
Impedance		50 Ohms Nominal
Corona Level Voltage		250 Volts at 70,000 ft.
MECHANICAL		
Connector Durability	3.15	The connector is to be tested and its mating connector shall be subjected to 500 insertion min. Withdrawal cycles / minute are not applicable. The connector shall show no evidence of mechanical failure and the connector shall meet the mating characteristic requirements.
Temperature		-65°C to +165°C
Force to Engage and Disengage	3.5.1	The Force to Engage and Disengage shall not exceed 2 inch-pounds (0.226 Nm).
Longitudinal Force max.		Longitudinal force is not applicable.
ENVIRONMENTAL		
Corrosion (Salt Spray)	3.13	Specification MIL-STD-202, Method 101, Test Condition B. The salt solution shall be 5%.
Vibration	3.18	Specification MIL-STD-202, Method 204, Test Condition D.
Shock	3.19	Specification MIL-STD-202, Method 213, Test Condition I.
Thermal Shock	3.20	Specification MIL-STD-202, Method 107, Test Condition B, except high temperature shall be + 200°C.
Moisture Resistance	3.21	Specification MIL-STD-202, Method 106. Step 7b (vibration) shall be omitted. Insulation resistance shall be 200 megohms min. within 5 minutes of removal from humidity.

SMA PUSH-ON

1.	SMA Specifications/Interface Dimensions	107
2.	Connectors of Type SMA PUSH-ON	
	Locking with Non Locking Rear Nut	112
	Non Locking	113
3.	Adapters to SMA PUSH-ON	115

CONTENT

**INTRODUCTION
to PUSH-ON
CONNECTORS
& ADAPTERS**
Page 9

7/16 PUSH-ON
Page 15

BMA Page 27

N PUSH-ON
Page 45

SBX Page 61

SBY Page 85

SMA PUSH-ON

SMA Reverse Sex PUSH-ON
Page 119

SMP Page 131

TNC PUSH-ON
Page 193

CABLE ASSEMBLIES

with
**INTERCHANGEABLE
CONNECTORS**
Page 213

**Kits with
I./CONNECTORS**
Page 221

w/ **PUSH-ONs**
Page 225

**RAW CABLE
SPECIFICATIONS**
Page 245

RF MULTI PIN
Page 265

TOOLS
Page 271

**ASSEMBLY
INSTRUCTIONS**
Page 289

**SPECIAL
PRODUCTS
& SERVICES**
Page 353

APPENDIX

SMA PUSH-ON Connectors

DC - 18.0 GHz

Locking with Non-locking Rear Nut

Connector Part No.	Flexible Cable Type	Cable Code	Connector Code
2013-SM01-02	RG-316/U	32	SML
2015-SM01-02	RG-400/U	40	
2015-SM02-02	RG-142B/U	42	

Connector outer conductor is passivated stainless steel.
Center conductor is gold plated.

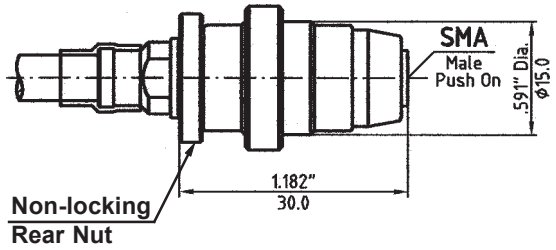

Dimensions shown are inches over millimeters. Standard units have stainless steel finish (last two digits of the P/N are -02). Interfaces are per MIL-C-39012. For details please refer to the beginning of this section.

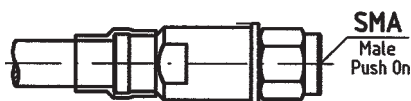

DC - 18.0 GHz **NON Locking**

Connector Part No.	Flexible Cable Type	Cable Code	Connector Code
2013-SM02-02	RG-316/U	32	SM
2015-SM03-02	RG-400/U	40	
2015-SM04-02	RG-142B/U	42	

Connector outer conductor is passivated stainless steel. Center conductor is gold plated.

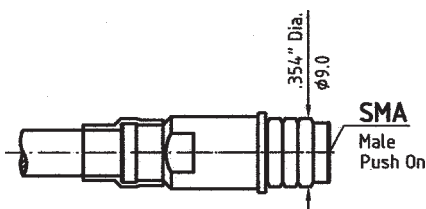

DC - 18.0 GHz **NON Locking**

Connector Part No.	Flexible Cable Type	Cable Code	Connector Code
2013-SM03-02	RG-316/U	32	SMR
2015-SM05-02	RG-400/U	40	
2015-SM06-02	RG-142B/U	42	

Connector outer conductor is passivated stainless steel. Center conductor is gold plated.

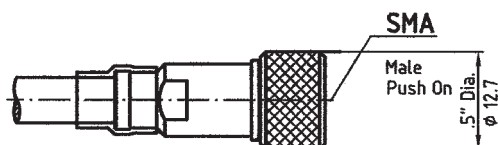

NON Locking

Connector Part No.	Flexible Cable Type	Cable Code	Connector Code
2013-SM04-02	RG-316/U	32	SMM
2015-SM07-02	RG-400/U	40	
2015-SM08-02	RG-142B/U	42	

Connector outer conductor is passivated stainless steel. Center conductor is gold plated.

Dimensions shown are inches over millimeters. Standard units have stainless steel finish (last two digits of the P/N are -02). Interfaces are per MIL-C-39012. For details please refer to the beginning of this section.

The Phase Adjuster ! DC to 40.0 GHz !

VSWR 1.20:1 max.*!

* for P/N LS-P140-KEKM1

Interested?
Please refer to
The '98 Handbook
Components



You need DC to 50.0 GHz? It shouldn't be a major problem, we are already working on it!
You need Phase Adjusters for lower frequency applications: DC-2, DC-12, DC-18, DC-26.5 GHz?
We have these standard units too, maybe ex stock!

Please ask for our Products in the Frequency Range of DC to 50 GHz:
Adapters, ANA Test Cables, Antennas, Attenuators, Blind Mate Connectors, Circulators, CDM-Components, Connectors (RF), Couplers, Custom Components, DC-Block Connectors & Adapters, Gain-Equalizers, Flexible Cable Assemblies, Isolators, Limiters, Mismatches, Multi Pin Connectors, Phase Shifters, Phase Stable Cable Assemblies, Precision Terminations, Push-On Connectors & Adapters, Semi Rigid Cable, Switches, Waveguide Components, Waveguide to Coax Adapters, etc.



Spectrum
Elektrotechnik GmbH

80905 Munich, Germany

P.O. Box 45 05 33

Fax: { 49 } (89) 354-804-90,

Telephone: { 49 } (89) 354-804-0

phas0596

SMA

PUSH-ON

1.	SMA Specifications/Interface Dimensions	107
2.	Connectors of Type SMA PUSH-ON	111
3.	SMA PUSH-ON Adapters (Connector Savers)	
	Locking with Non Locking Rear Nut	to SMA 116
	Non Locking	117
	Float Mount	118

CONTENT	
INTRODUCTION to PUSH-ON CONNECTORS & ADAPTERS	Page 9
7/16 PUSH-ON	Page 15
BMA	Page 27
N PUSH-ON	Page 45
SBX	Page 61
SBY	Page 85
SMA PUSH-ON	
SMA Reverse Sex PUSH-ON	Page 119
SMP	Page 131
TNC PUSH-ON	Page 193
CABLE ASSEMBLIES	
with INTERCHANGEABLE CONNECTORS	Page 213
Kits with I./CONNECTORS	Page 221
w/ PUSH-ONs	Page 225
RAW CABLE SPECIFICATIONS	Page 245
RF MULTI PIN	Page 265
TOOLS	Page 271
ASSEMBLY INSTRUCTIONS	Page 289
SPECIAL PRODUCTS & SERVICES	Page 353
APPENDIX	

SMA Push-On Adapters

DC - 18.0 GHz

Locking with Non-locking Rear Nut

Adapter Part No.	8006-SM21-02
Connector Config.	SMA Push-On to SMA-f
Frequency Range	DC to 26.5 GHz
VSWR	1.20 : 1 max.

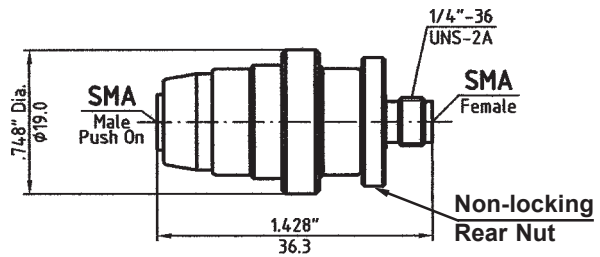

Connector outer conductor is passivated stainless steel.
Center conductor is gold plated.

Dimensions shown are inches over millimeters. Standard units have stainless steel finish (last two digits of the P/N are -02). Interfaces are per MIL-C 39012, MIL-C-87104/2, MIL-C-3643, MIL-STD-348, IEC-169-7, IEC-457-2, DIN 47 223, DIN 47 226, DIN 47 298, where applicable. For details please refer to the beginning of this section.

NON Locking

Adapter Part No.	8001-SM21-02
Connector Config.	SMA Push-On to SMA-f
Frequency Range	DC to 26.5 GHz
VSWR	1.20 : 1 max.

Connector outer conductor is passivated stainless steel.
Center conductor is gold plated.

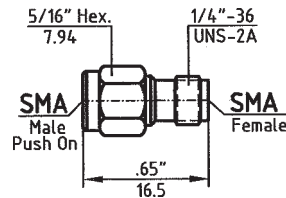

NON Locking

Adapter Part No.	8003-SM21-02
Connector Config.	SMA Push-On to SMA-f
Frequency Range	DC to 26.5 GHz
VSWR	1.20 : 1 max.

Connector outer conductor is passivated stainless steel.
Center conductor is gold plated.

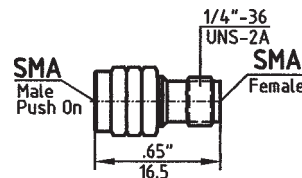

NON Locking

Adapter Part No.	8005-SM21-02
Connector Config.	SMA Push-On to SMA-f
Frequency Range	DC to 26.5 GHz
VSWR	1.20 : 1 max.

Connector outer conductor is passivated stainless steel.
Center conductor is gold plated.

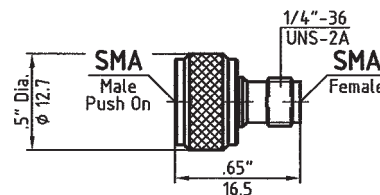

Easier Handling with the enlarged coupling nut.

Dimensions shown are inches over millimeters. Standard units have stainless steel finish (last two digits of the P/N are -02). Interfaces are per MIL-C 39012, MIL-C-87104/2, MIL-C-3643, MIL-STD-348, IEC-169-7, IEC-457-2, DIN 47 223, DIN 47 226, DIN 47 298, where applicable. For details please refer to the beginning of this section.

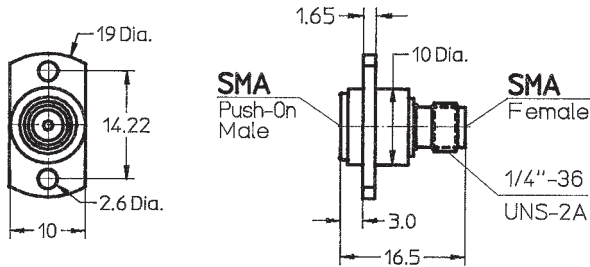

**SMA Push-On Two Hole Flange Mount
Floating Rear Mount Connector Saver**

NON Locking

Adapter Part No.	8004-SM21-02
Connector Config.	SMA Push-On to SMA-f
Frequency Range	DC to 26.5 GHz
VSWR	1.20 : 1 max.

Connector outer conductor is passivated stainless steel.
Center conductor is gold plated.

Float Mount Application Notes can be supplied on request.

Dimensions shown are inches over millimeters. Standard units have stainless steel finish (last two digits of the P/N are -02). Interfaces are per MIL-C 39012, MIL-C-87104/2, MIL-C-3643, MIL-STD-348, IEC-169-7, IEC-457-2, DIN 47 223, DIN 47 226, DIN 47 298, where applicable. For details please refer to the beginning of this section.