

# SBY

## CONTENT

**INTRODUCTION**  
to PUSH-ON  
CONNECTORS  
& ADAPTERS  
Page 9

**7/16** PUSH-ON  
Page 15

**BMA** Page 27

**N** PUSH-ON  
Page 45

**SBX** Page 61

## SBY

**SMA** PUSH-ON  
Page 107

**SMA** PUSH-ON  
Reverse  
Sex Page 119

**SMP** Page 131

**TNC** PUSH-ON  
Page 193

## CABLE ASSEMBLIES

with  
**INTERCHANGEABLE  
CONNECTORS**  
Page 213

**Kits with  
I./CONNECTORS**  
Page 221

w/ **PUSH-ONs**  
Page 225

**RAW CABLE  
SPECIFICATIONS**  
Page 245

**RF MULTI PIN**  
Page 265

**TOOLS**  
Page 271

**ASSEMBLY  
INSTRUCTIONS**  
Page 289

**SPECIAL  
PRODUCTS  
& SERVICES**  
Page 353

## APPENDIX

<b>1. SBY Specifications/Interface Dimensions</b>	<b>86</b>
<b>2. Connectors of Type SBY</b>	<b>95</b>
<b>3. Adapters to SBY</b>	<b>101</b>

**SBY** (Spectrum-Blind Mate-Y) push-on connectors were developed in 1993 for the same program the SBX was needed, interconnecting high power microwave modules, using direct mount or floating rear mount. **SBY** high performance connectors meet high power requirements, combined with microwave multiple interconnects. The connectors can be integrated into the housing of the component so that the connection even cannot be recognized from the outside. **SBY** connectors are specifically used for packaging and interconnecting those power microwave modules, drawers and racks in state-of-the-art systems that do not allow longer system down time. **SBY** push-on connectors allow replacement of faulty high power microwave modules within seconds. A typical method of interlocking modules is using lock screws.

**SBY** (Spectrum-Blind Mate-Y) female connectors are available, offering radial misalignment with the mating plug connector. A spring mechanism separates the connector interface from the flange housing and allows floating for blind mating purposes.

**SBY** (Spectrum-Blind Mate-Y) connectors are designed for high power, operating to 12.0 GHz. Precision design leads to lowest VSWR. Excellent electrical performance means little reflected power, which is the prerequisite for superior performance at higher power applications.

**SBY** (Spectrum-Blind Mate-Y) connectors are also available as cable connectors for several standard **semi-rigid** cables, **low density semi-rigid** cables, standard **flexible** cables and **low density flexible** cables. The availability of **SBY** connectors allows easy interconnection of microwave power components. Standard units are available in bulkhead or panel mount designs for solder and compression clamp attachment. Female cable connectors can be obtained in float or rigid mount. **SBY** float mount connectors are ideally suited for axial and radial misalignment. They employ a spring mechanism that separates the connector interface from the flange housing and allows the floating. Radial float mount connectors are used for applications requiring a radial misalignment of more than +/- 0.045 inches (1.14mm).

Some test equipment may not be supplied with **SBY** test port connectors. Therefore an adequate number of between series instrument grade adapters to other important connector series are available, such as 7/16, N and SMA.

**SBY** float mount adapters are available to 7/16 and N. Those adapters are of particular interest in applications where components are using several **SBY** connectors in parallel, as mounting tolerances and misalignment have to be taken into consideration, and connection at the other end of the adapter is supposed to be made by cable assemblies using those other standard connectors of types 7/16 or N.

Spectrum Elektrotechnik GmbH is a very innovative company, offering special services in engineering in order to meet the customer's needs to perfection.

When using blind mate connectors in an application, careful consideration has to be given to choosing the right connector series, the appropriate connector model within that series, and the correct mounting features. Spectrum Elektrotechnik GmbH does offer besides the **SBY** series, also **SBX**, **BMA** and **SMP** blind mate connectors, and all those series are shown in this Handbook. This makes it easy for the customer to identify the best connector or connectors for his system. A system also may use several or all of the blind mate connectors offered. Important parameters for identifying the proper connector and its series are:

- \* **POWER REQUIREMENT**
- \* **OPERATING FREQUENCY**
- \* **RIGID OR FLOAT MOUNT CONNECTORS**
- \* **CONNECTOR-TO-CONNECTOR FIXED TOLERANCES**
- \* **CONNECTOR-TO-CONNECTOR FLOAT TOLERANCES**
- \* **MATING FORCES**
- \* **FLOAT MOUNT SPRING LOADING**
- \* **CONNECTOR PACKAGING DENSITY IN MULTIPLE CONNECTOR ARRAYS**
- \* **PANEL DEFLECTION**

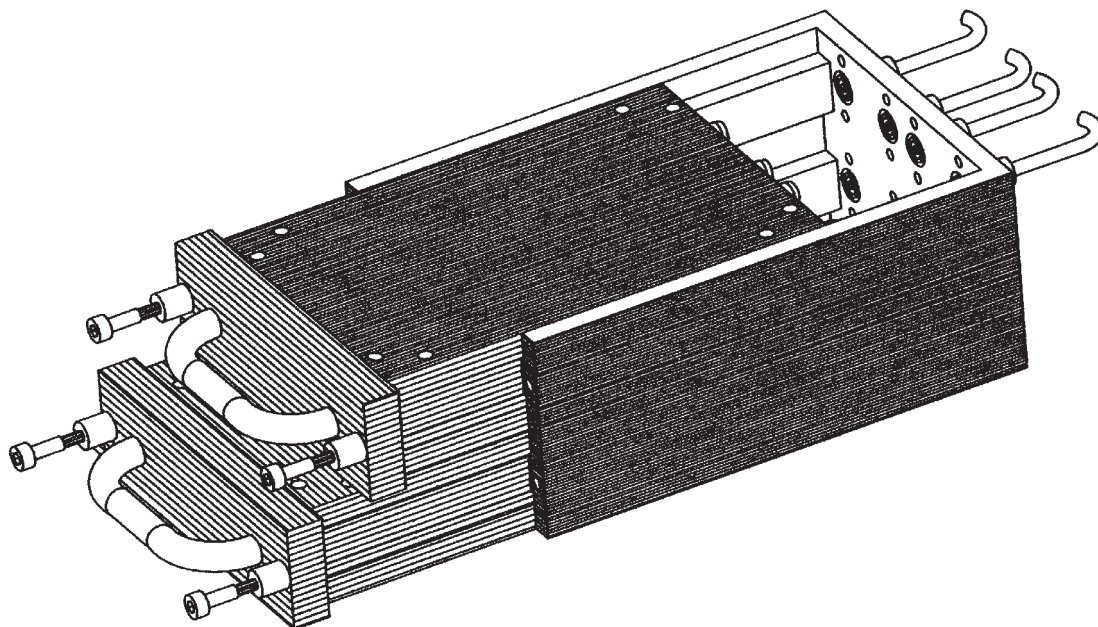

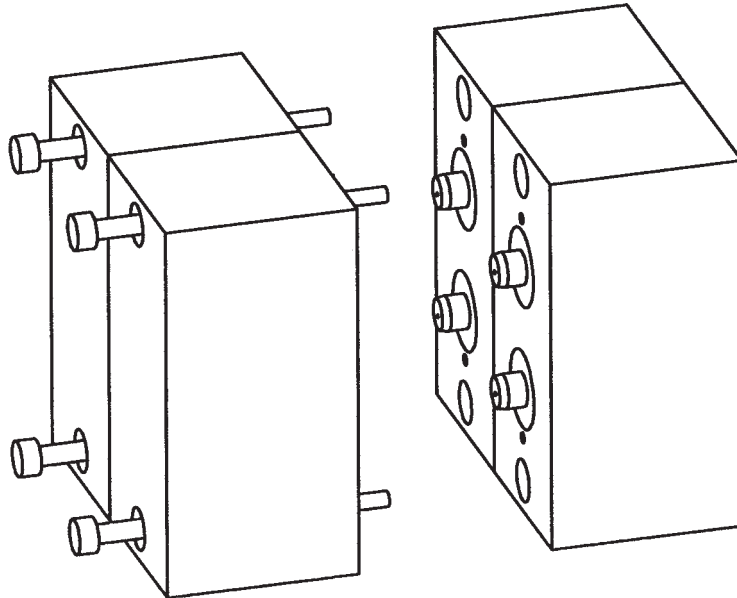

For applications such as modularized MIC to MIC packages, only rigid mount connectors can be used. Relatively tight tolerances need to be held, as the rigid mount SBY does not accommodate radial misalignment. Axial misalignment should be avoided when the connector is used in high power environment. As in most cases only one SBY connector per module is used as power input or output, the interlocking screws can accommodate certain misalignment. A typical method of interlocking modules is using jack screws.

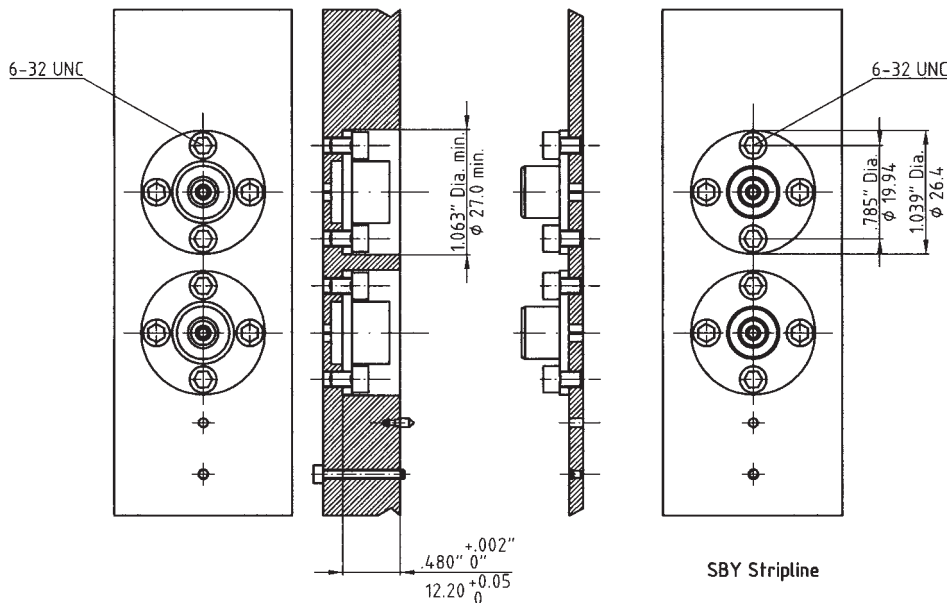

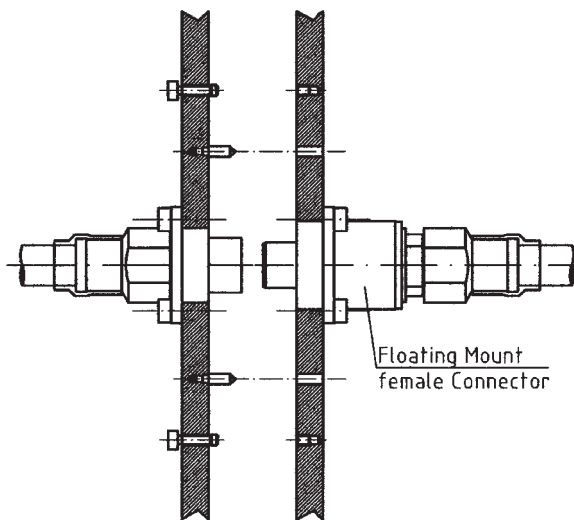

**SBY** (Spectrum **B**lind **M**ate-**Y**) female connectors are available, offering radial misalignment with the mating plug connector. A spring mechanism separates the connector interface from the flange housing and allows floating for blind mating purposes. The spring mechanism is aligning the mating connectors, therefore the forces are transmitted to the mounting panel. Under extreme mismatch conditions the mating forces can be considerably high when using several connectors. This can cause bowing of the mounting panel.

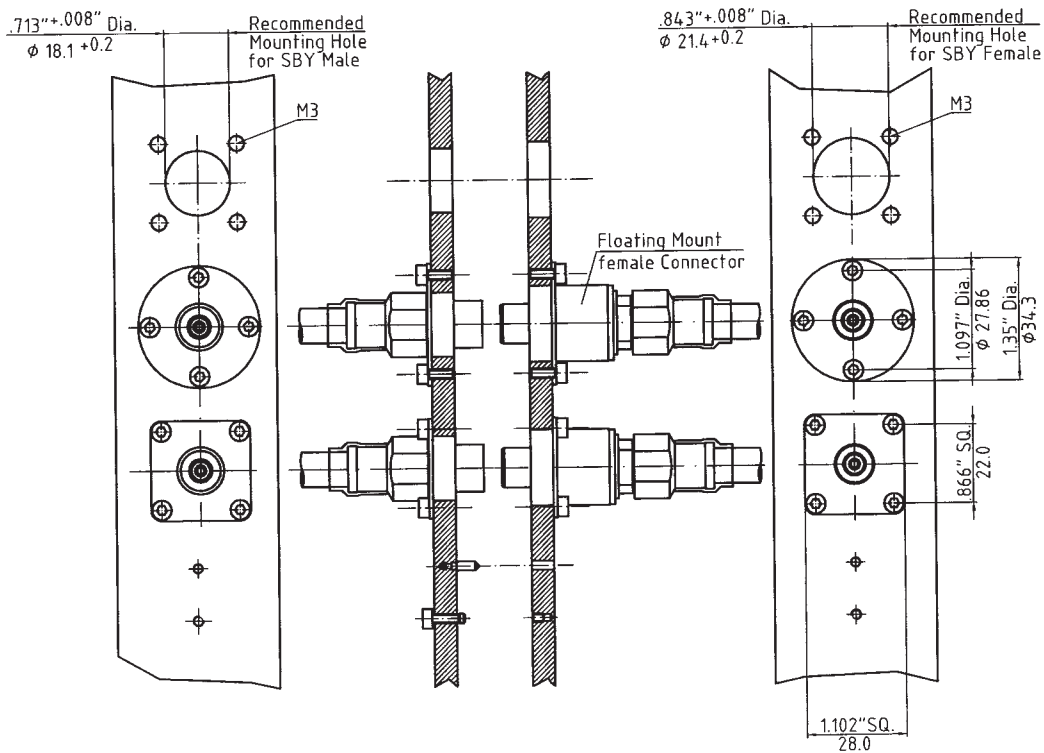

e:/quike98/sby.ppt6

When using several SBY blind mate connectors at a component, on a module to motherboard or rack or panel application, the design must take into consideration the interface mating forces to engage and disengage the connectors, and the spring pre-load forces in floating mount cases. Disregarding this, distortion of mounting plates and panels can occur, preventing proper mating of the connectors, resulting into degraded performance of the component. Considering the panel or motherboard as a beam under deflection can be used as a good approximation for calculating the amount of distortion or bowing. But it has to be noted that the formulas and tables given below and to the right are not taken into consideration when forces are being applied from different angles, or operation in the event of additional stress because of the occurrence of multiple forces.

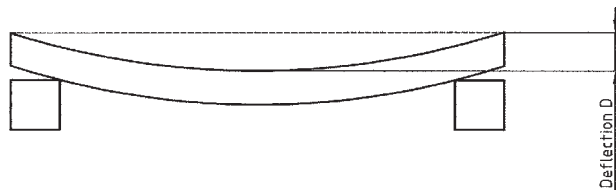
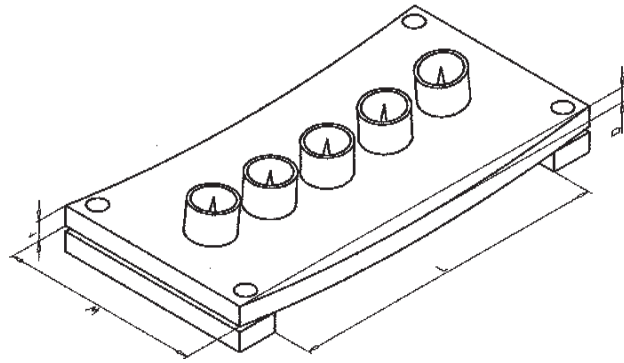

### Material Properties

Material	Yield Strength $R_y$		Modulus of Elasticity $E$	
	PSI	N/mm <sup>2</sup>	PSI	N/mm <sup>2</sup>
Al Mg 3	10,200...14,500	70 ... 100	$10.3 \times 10^6$	71,000
Al Mg 4.5 Mn	18,100	125	$10.2 \times 10^6$	70,000
Al Mg Si 0.5	23,200	160	$10.2 \times 10^6$	70,000
Al Mg Si 1	16,000...37,000	110...255	$10.2 \times 10^6$	70,000
Al Mg Si Pb	40,000	275	$10.2 \times 10^6$	70,000
X5 CrNi 18 9 (1.4301)	50,800	350	$30.5 \times 10^6$	210,000
X12 CrNiS 18 8 (1.4305)	58,100	400	$30.5 \times 10^6$	210,000
X10 CrNiMoTi 18 10 (1.4571)	138,000	950	$30.5 \times 10^6$	210,000
Fe 360 B (St 37-2)	34,100	235	$30.5 \times 10^6$	210,000
Fe 590-2 (St 60-2)	48,600	335	$30.5 \times 10^6$	210,000

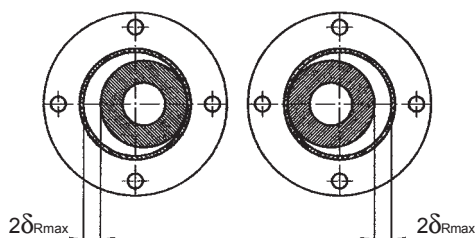
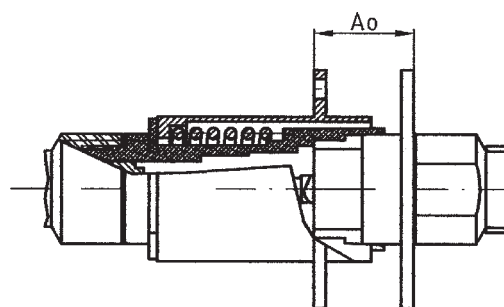
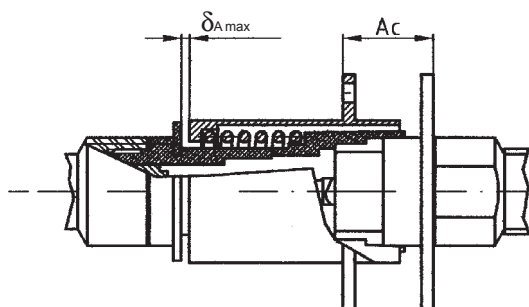
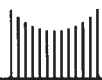

**A<sub>c</sub>:** distance between mounting surfaces with max. axial misalignment

**A<sub>0</sub>:** distance between mounting surfaces with no axial misalignment

$$A_0 = A_c + \delta_{A_{max}}$$

**δ<sub>A</sub>:** axial misalignment

$$\delta_{A_{max}} = 0.05" (1.27\text{mm})$$

**δ<sub>R</sub>:** radial misalignment

$$\delta_{R_{max}} = 0.04" (1.02\text{mm})$$

**SBY** (Spectrum Blind Mate-Y) female connectors are available, offering radial misalignment with the mating plug connector. A spring mechanism separates the connector interface from the flange housing and allows floating for blind mating purposes. The spring mechanism is aligning the mating connectors, therefore the forces are transmitted to the mounting panel. Under extreme mismatch conditions the mating forces can be considerably high when using several connectors. This can cause bowing of the mounting panel.

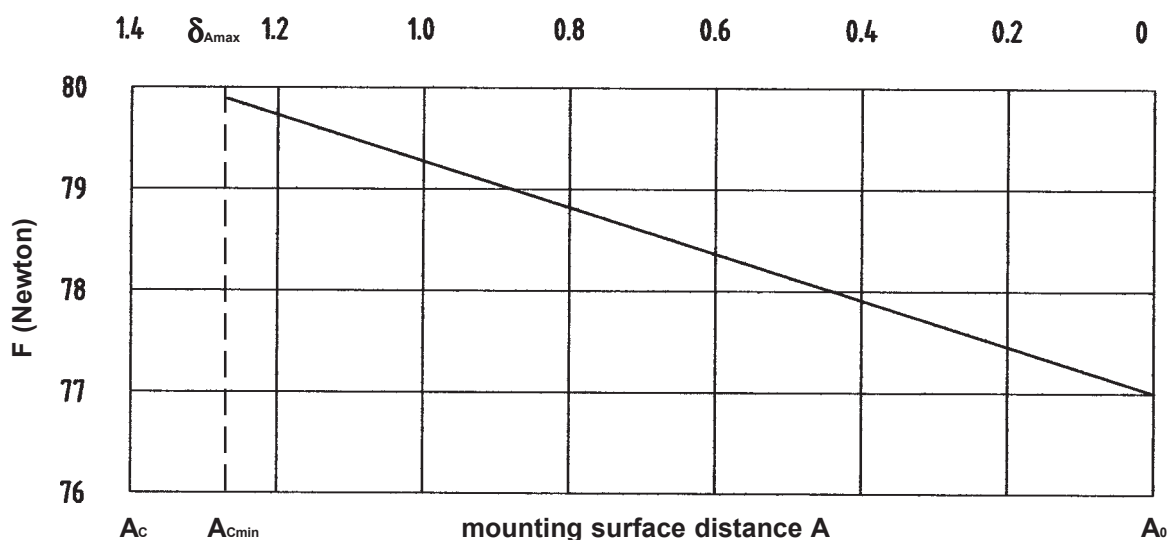

e:/quike98/sby.ppt6



		Formulae	
Ultimate Moment of Resistance	$M_u \text{ [mm}^3\text{]}$	$M_u = \frac{wt^2}{6}$	$w$ = width of the panel [mm] $t$ = thickness of the panel [mm]
Moment of a Beam	$I \text{ [mm}^3\text{]}$	$I = \frac{wt^3}{12}$	$w$ = width of the panel [mm] $t$ = thickness of the panel [mm]
Maximum Deflection	$D \text{ [mm]}$	$D < \frac{\sum F_D L^3}{48 E I}$	$\sum F_D$ = Sum of all forces applied to the plate [N] $L$ = Length of the panel [mm] $E$ = Modulus of Elasticity $\left[\frac{N}{\text{mm}^2}\right]$ $I$ = Moment of Inertia $[\text{mm}^4]$
Ultimate Tensile Stress	$\sigma \left[\frac{N}{\text{mm}^2}\right]$	$\sigma < \frac{\sum F_D L}{4 M_u}$ The tensile stress must be less than the yield strength.	$\sum F_D$ = Sum of all forces applied to the panel [N] $L$ = Length of the panel [mm] $M_u$ = Ultimate Moment of Resistance $[\text{mm}^3]$

**EXAMPLE, USING 2 PIECES FLOAT MOUNT SBY CONNECTORS:**

**Mating Force of SBY: 70 N**

$$\sum F_{M(2 \text{ connectors})} = 2 \times 70\text{N} = 140\text{ N}$$

But: The maximum force for 1.27 mm axial misalignment, which is the maximum possible displacement, reads 154N, as shown in the diagram on page 91. Therefore the greater displacement force will be used in the following calculations instead:

**Max. Displacement Force of SBY: 79.9 N**

$$\sum F_{D(2 \text{ connectors})} = 2 \times 79.9\text{N} = 159.8\text{ N}$$

**Aluminum mounting panel of Al Mg Si 0.5:**

$$L \times w \times t = 100\text{mm} \times 12.7\text{mm} \times 6.35\text{mm}.$$

**Modulus of Elasticity:**

$$E = 70,000\text{ N/mm}^2$$

**Yield Strength:**

$$R_y = 160\text{ N/mm}^2, \text{ as shown in the table.}$$

**Ultimate Moment of Resistance:**  $M_u = \frac{wt^2}{6} = \frac{12.7\text{mm} \times (6.35\text{mm})^2}{6} = 85.3\text{ mm}^2$

**Moment of a Beam:**  $I = \frac{wt^3}{12} = \frac{12.7\text{mm} \times (6.35\text{mm})^2}{12} = 271.0\text{ mm}^4$

**Maximum Deflection:**  $D < \frac{\sum F_D L^3}{48 E I} = \frac{159.8\text{N} \times (100\text{mm})^3}{48 \times 70,000\text{N/mm}^2 \times 271.0\text{mm}^4} = 0.18\text{ mm}$

**Ultimate Tensile Stress:**  $\sigma < \frac{\sum F_D L}{4 M_u} = \frac{159.8\text{N} \times 100\text{mm}}{4 \times 85.3\text{ mm}^3} = 46.8\text{ N/mm}^2$

The maximum deflection calculated in this example is less than the max. allowable axial misalignment of 1.27mm, as allowed by definition for the SBY float mount. Additionally, in the calculation it is assumed that the forces of all 2 connectors are applying in the center of the panel. Therefore additional forces, as contributed by radial misalignment, transverse and shearing forces may be disregarded. The use of the panel chosen in this example for 2 SBY's seems to be very safe for this application.



The specifications below are general specifications for all SBY connectors. Specific Data for VSWR, Insertion loss, R.F. leakage etc., are available from the factory upon request. Specifications in the following table are recommended for any procurement documents or drawings. In the event of any conflict between these specifications and other documentation, these specifications shall govern. These specifications are subject to change according to the latest revision.

REQUIREMENT	GENERAL SPECIFICATIONS
<b>GENERAL</b>	
Standard Materials	STEEL corrosion resistant 1.4305 per DIN 17440 (QQ-S-764, class 303 or ASTM-A-582-80). ALUMINUM AlMg4.5Mn per DIN 1725, AlMgSi0.5 per DIN 1725, AlMgSi1 per DIN 1725 (6061-T6 per QQ-A-225/8). BRASS CuZn39Pb3 per DIN 17660 (QQ-B-626, half hard). COPPER BERYLLIUM 33-25 CuBe2Pb H per DIN 17666 (QQ-C-530). TFE Fluorocarbon per DIN 52900 (MIL-P-19468 and L-P403). SILICONE RUBBER per DIN 3771 (MIL-R-5847 and ZZ-R-765, Class II B,) Grade 50 - 75. BORRMIUM NITRITE Dielectric for high power applications per inhouse specification.
Finish for	Center Contacts shall be gold plated to a minimum thickness of .00005 inch (1.27 µm) in accordance with MIL-G-45204, Type II, Grade C. Outer conductors shall be gold plated to a thickness of .00003 inch (0.8 µm) per MIL-G-45204, Type II, Grade C, or silver plated to a thickness of .0001 inch (2.5 µm) per QQ-S-365. Shall be passivated per QQ-P-35 or gold plated to a thickness of .00003 inch (0.8 µm) per MIL-G-45204, Type II, Grade C. Conductive Parts shall have an iridited finish per MIL-C-5541. Other parts, such as Coupling Nuts and Back-Bodies shall be anodized per MIL-A-8625. Gold plated to a thickness of .00003 inch (0.8 µm) min. per MIL-45204, Type II, Grade C, or nicle plated to a thickness of .0002 inch (5µm) per QQ-N-290, grade E, or silver plated to a thickness of .0001 inch (2.5 µm) per QQ-S-365. Imoloy .0001 inch (2.5 µm) min. plating, consisting of 55% Copper / 20% Zinc / 25% Tin (on special request).
COPPER BERYLLIUM	
STAINLESS STEEL	
ALUMINUM	
BRASS	
VARIOUS	Imoloy .0001 inch (2.5 µm) min. plating, consisting of 55% Copper / 20% Zinc / 25% Tin (on special request).
Design	The design shall be such that the outline dimensions in this catalog are met. In addition, the assembled connector shall meet the interface dimensions.
<b>ELECTRICAL</b>	
Frequency Range	DC - 12.0 GHz min.
Insulation Resistance	The insulation resistance shall not be less than 5.000 megohms.
Voltage Standing Wave Ratio (VSWR)	1.015 + .003 * f (GHz)
Contact Resistance	The center contact resistance drop shall not exceed 1.0 milliohms and the outer contact resistance drop shall not exceed 1.5 milliohms.
Dielectric Withstanding Voltage	The magnitude of the test voltage shall be 2.300 volts rms at sea level.
RF High Potential Withstanding Voltage	The RF high potential withstanding voltage is 1.300 volts rms at 5 MHz. Leakage is not applicable.
RF Leakage	RF Leakage is not applicable
Insertion Loss	(.05 SQT(f(GHz))) dB
<b>MECHANICAL</b>	
Connector Durability	The connector is to be tested and its mating connector shall be subjected to 5000 insertions. Withdrawal cycles not applicable. The connector shall show no evidence of mechanical failure and the connector shall meet the mating characteristic requirements.
Cable Retention Force	Cable Retention Force is not applicable.
Coupling Nut Retention Force	Coupling Nut Retention Force is not applicable.
Force to Engage and Disengage	Force to engage and disengage is not applicable.
Longitudinal Force max.	Longitudinal force is not applicable.
Mating Characteristics	Mating Characteristics are not applicable
Recommended Mating Torque	Recommended Mating Torque is not applicable.
<b>ENVIRONMENTAL</b>	
Corrosion (Salt Spray)	Specification MIL-STD-202, Method 101, Test Condition B. The salt solution shall be 5%.
Vibration	Specification MIL-STD-202, Method 204, Test Condition B.
Shock	Specification MIL-STD-202, Method 213, Test Condition I.
Thermal Shock	Specification MIL-STD-202, Method 107, Test Condition B, except high temperature shall be + 200°C.
Moisture Resistance	Specification MIL-STD-202, Method 106. Step 7b (vibration) shall be omitted. Insulation resistance shall be 200 megohms min. within 5 minutes of removal from humidity.
Corona Level	The connector shall not exhibit breakdown (corona) when the applied voltage is 2800 volts rms and the altitude is 0 feet.

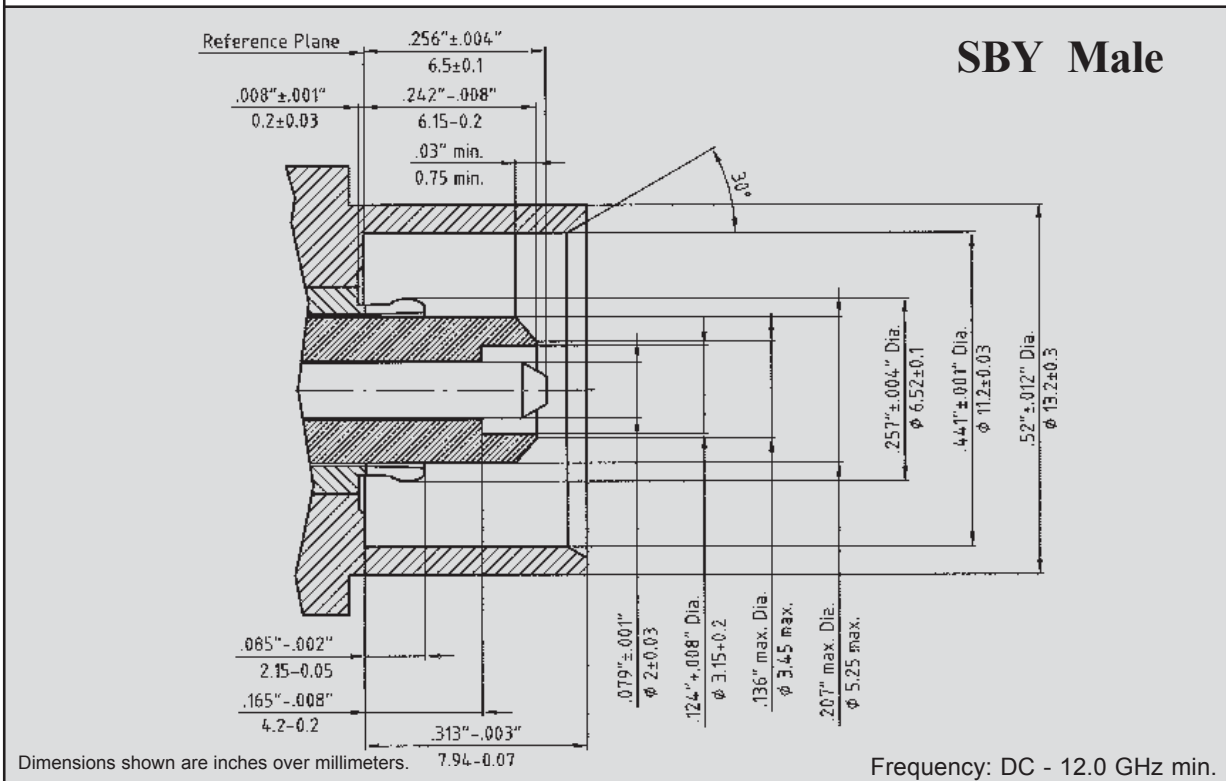
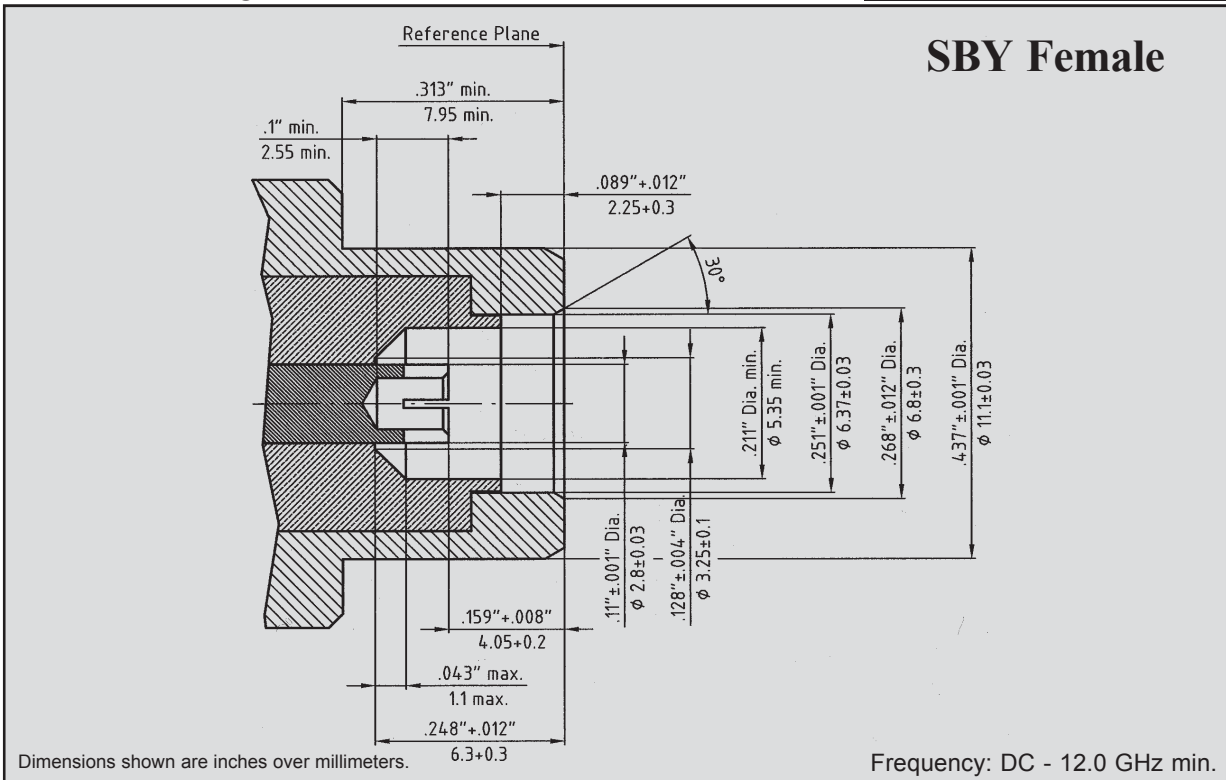

# SBY

<b>1.</b>	<b>SBY Specifications/Interface Dimensions</b>	<b>86</b>
<b>2.</b>	<b>Semi-Rigid Float Mount Connectors</b>	<b>96</b>
	<b>Flex. Cable Float Mount Connectors</b>	<b>98</b>
	<b>Circuit Board Connectors</b>	<b>100</b>
<b>3.</b>	<b>Adapters to SBY</b>	<b>101</b>

CONTENT	
INTRODUCTION to PUSH-ON CONNECTORS & ADAPTERS	Page 9
7/16 PUSH-ON	Page 15
BMA	Page 27
N PUSH-ON	Page 45
SBX	Page 61
SBY	
SMA PUSH-ON	Page 107
SMA Reverse Sex	PUSH-ON Page 119
SMP	Page 131
TNC PUSH-ON	Page 193
CABLE ASSEMBLIES	
with INTERCHANGEABLE CONNECTORS	Page 213
Kits with I./CONNECTORS	Page 221
w/ PUSH-ONs	Page 225
RAW CABLE SPECIFICATIONS	Page 245
RF MULTI PIN	Page 265
TOOLS	Page 271
ASSEMBLY INSTRUCTIONS	Page 289
SPECIAL PRODUCTS & SERVICES	Page 353
APPENDIX	

e:/quike98/sby.pnt6

# SBY Semi-Rigid Float Mount Connectors

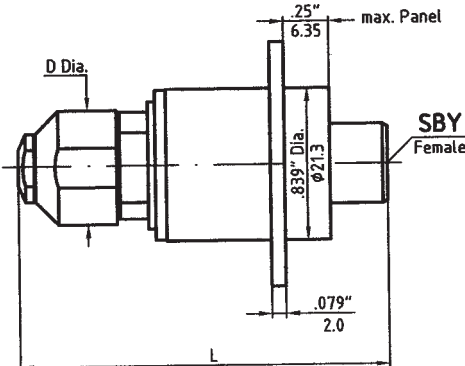
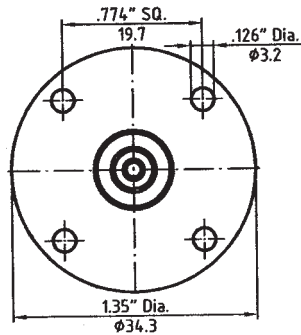

DC - 12.0 GHz

## SBY-Female Float Mount for Semi-Rigid Cables

Connector Part No.	S/R Cable	Cable Part No.	L	Ø D	Conn. Code
7903-6001-02	.141"	421-669	In Development		YF4
		421-669-1			
		421-669-3			
7906-6001-02	.250"	421-252	2.008"	.63"	YF4
		421-252-1	51.0	16.0	
		421-252-3			
7906-6002-02	.250" LL	421-336	2.008"	.63"	YF4
		421-336-1	51.0	16.0	
		421-336-3			

Connector outer conductor is passivated stainless steel. Center conductor is gold plated. LL= Low density dielectric.

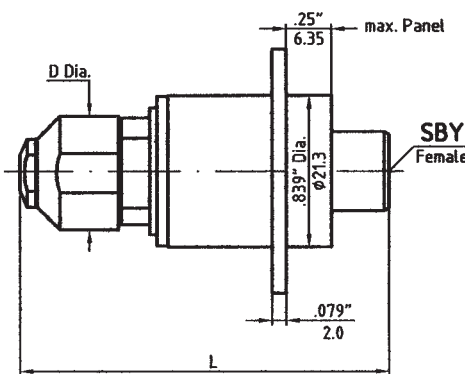
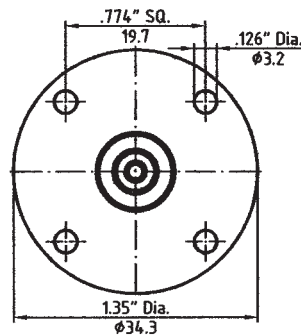

DC - 12.0 GHz

## SBY-Female Float Mount for Semi-Rigid Cables

Connector Part No.	S/R Cable	Cable Part No.	L	Ø D	Conn. Code
7903-6002-02	.141"	421-669	In Development		YFR
		421-669-1			
		421-669-3			
7906-6003-02	.250"	421-252	2.008"	.63"	YFR
		421-252-1	51.0	16.0	
		421-252-3			
7906-6004-02	.250" LL	421-336	2.008"	.63"	YFR
		421-336-1	51.0	16.0	
		421-336-3			

Connector outer conductor is passivated stainless steel. Center conductor is gold plated. LL= Low density dielectric.

Dimensions shown are inches over millimeters. Standard units have stainless steel finish (last two digits of the P/N are -02). Interfaces are per Spectrum Elektrotechnik GmbH Specifications. For details please refer to the beginning of this section.

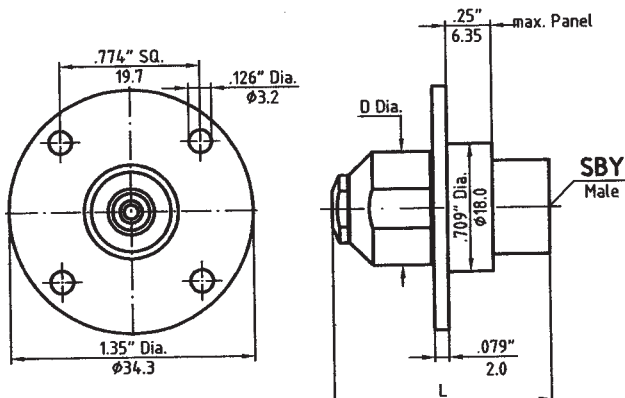

DC - 12.0 GHz  
**SBY-Male for Semi-Rigid Cables**

Connector Part No.	S/R Cable	Cable Part No.	L	Ø D	Conn. Code
<b>7903-7001-02</b>	.141"	421-669 421-669-1 421-669-3	In Development		YM
<b>7906-7001-02</b>	.250"	421-252 421-252-1 421-252-3	1.165"	.63"	
<b>7906-7002-02</b>	.250" LL	421-336 421-336-1 421-336-3	1.165"	.63"	

Connector outer conductor is passivated stainless steel. Center conductor is gold plated. LL= Low density dielectric.

e:/quike98/sby.pnt6

Dimensions shown are inches over millimeters. Standard units have stainless steel finish (last two digits of the P/N are -02). Interfaces are per Spectrum Elektrotechnik GmbH Specifications. For details please refer to the beginning of this section.

# SBY Flexible Cable Float Mount Connectors

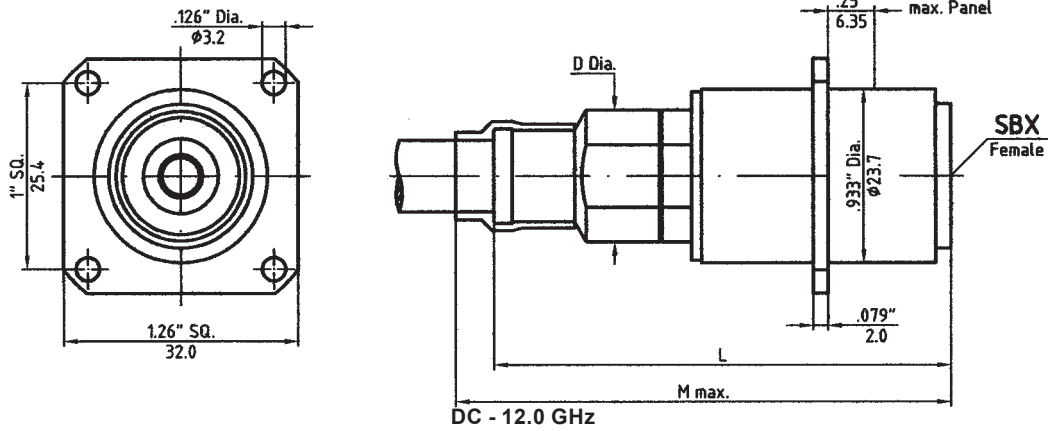

DC - 12.0 GHz

## SBY-Female Float Mount for Flexible Cables

Connector Part No.	Cable Type	Cable Code	L	M	Ø D Dia.	Conn. Code
7915-6001-02	RG-142B/U	42	In Development		.709"	YF4
7915-6002-02	RG-400/U	40	In Development			
7917-6001-02	RG-214/U	21	2.346" 59.6	4.134" 105.0		

Connector outer conductor is passivated stainless steel. Center conductor is gold plated.

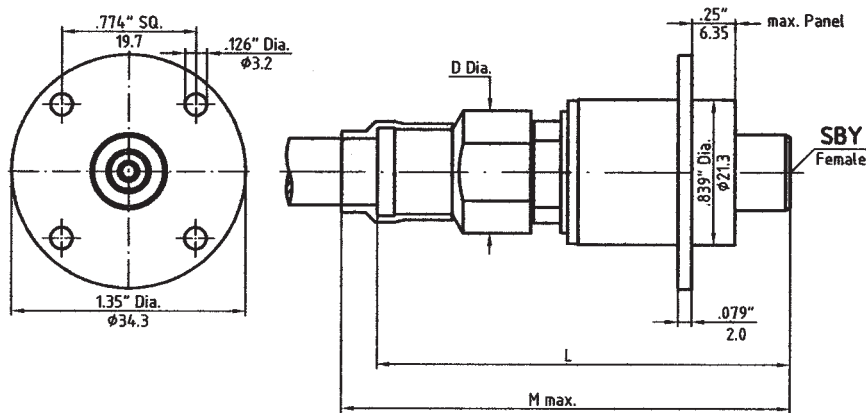

DC - 12.0 GHz

## SBY-Female Float Mount for Flexible Cables

Connector Part No.	Cable Type	Cable Code	L	M	Ø D Dia.	Conn. Code
7915-6003-02	RG-142B/U	42	In Development		.709"	YFR
7915-6004-02	RG-400/U	40	In Development			
7917-6002-02	RG-214/U	21	2.346" 59.6	4.134" 105.0		

Connector outer conductor is passivated stainless steel. Center conductor is gold plated.

Dimensions shown are inches over millimeters. Standard units have stainless steel finish (last two digits of the P/N are -02). Interfaces are per Spectrum Elektrotechnik GmbH Specifications. For details please refer to the beginning of this section.

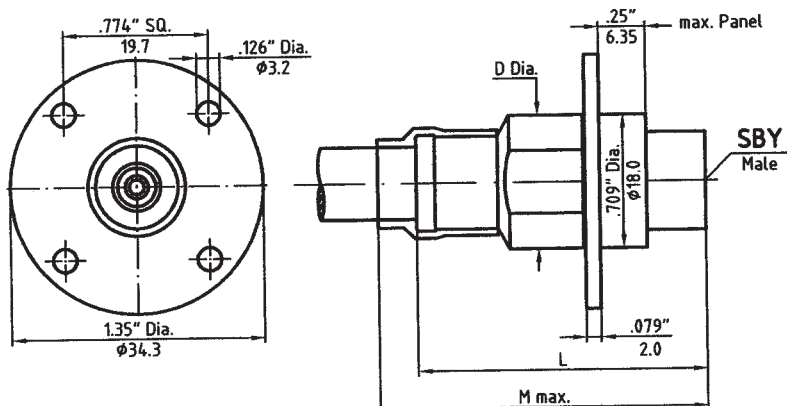

DC - 12.0 GHz  
SBY-Male for Flexible Cables

Connector Part No.	Cable Type	Cable Code	L	M	Ø D Dia.	Conn. Code
7915-7001-02	RG-142B/U	42	In Development			YM
7915-7002-02	RG-400/U	40	In Development			
7917-7001-02	RG-214/U	21	1.409" 35.8	3.228" 82.0	.709" 18.0	

Connector outer conductor is passivated stainless steel. Center conductor is gold plated.

e:/quike98/sby.ppt6

Dimensions shown are inches over millimeters. Standard units have stainless steel finish (last two digits of the P/N are -02). Interfaces are per Spectrum Elektrotechnik GmbH Specifications. For details please refer to the beginning of this section.



# SBY Circuit Board Connectors



## SBY Female Flange Mount Slotted Termination

Connector Part No.	<b>7999-7002-02</b>
Frequency Range	<b>DC - 12.0 GHz</b>

Connector outer conductor is passivated stainless steel.  
Center conductor is gold or/and silver plated.

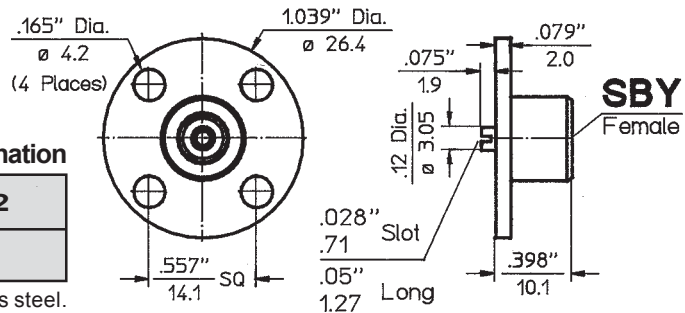

## SBY Female Flange Mount Tab Termination

Connector Part No.	<b>7999-7003-02</b>
Frequency Range	<b>DC - 12.0 GHz</b>

Connector outer conductor is passivated stainless steel.  
Center conductor is gold or/and silver plated.

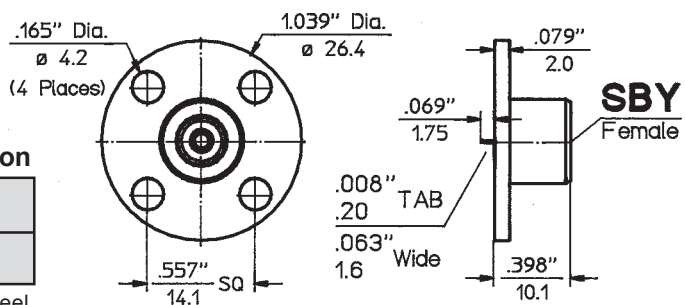

## SBY Male Flange Mount Slotted Termination

Connector Part No.	<b>7999-6003-02</b>
Frequency Range	<b>DC - 12.0 GHz</b>

Connector outer conductor is passivated stainless steel.  
Center conductor is gold or/and silver plated.

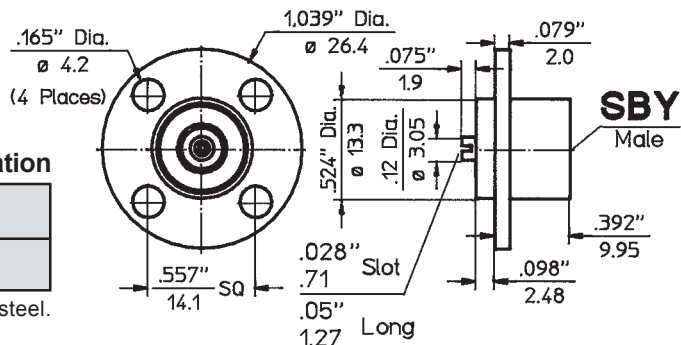

## SBY Male Flange Mount Tab Termination

Connector Part No.	<b>7999-6002-02</b>
Frequency Range	<b>DC - 12.0 GHz</b>

Connector outer conductor is passivated stainless steel.  
Center conductor is gold or/and silver plated.

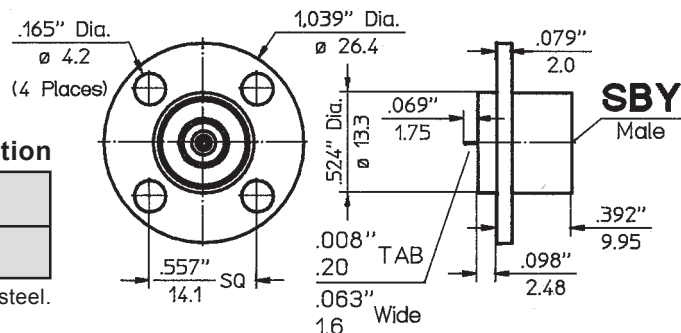

Dimensions shown are inches over millimeters. Standard units have stainless steel finish (last two digits of the P/N are -02). Interfaces are per Spectrum Elektrotechnik GmbH Specifications. For details please refer to the beginning of this section.

# SBY

<b>1.</b>	<b>SBY Specifications/Interface Dimensions</b>	<b>86</b>
<b>2.</b>	<b>Connectors of Type SBY</b>	<b>95</b>
<b>3.</b>	<b>Adapters SBY to 7/16</b>	<b>102</b>
	<b>Adapters SBY to N</b>	<b>103</b>
	<b>Adapters SBY to SMA</b>	<b>104</b>
	<b>Float Mount Adapters SBY to N</b>	<b>106</b>

<b>CONTENT</b>	
<b>INTRODUCTION to PUSH-ON CONNECTORS &amp; ADAPTERS</b>	Page 9
<b>7/16 PUSH-ON</b>	Page 15
<b>BMA</b>	Page 27
<b>N PUSH-ON</b>	Page 45
<b>SBX</b>	Page 61
<b>SBY</b>	
<b>SMA PUSH-ON</b>	Page 107
<b>SMA Reverse Sex PUSH-ON</b>	Page 119
<b>SMP</b>	Page 131
<b>TNC PUSH-ON</b>	Page 193
<b>CABLE ASSEMBLIES</b>	
with <b>INTERCHANGEABLE CONNECTORS</b>	Page 213
<b>Kits with I./CONNECTORS</b>	Page 221
w/ <b>PUSH-ONs</b>	Page 225
<b>RAW CABLE SPECIFICATIONS</b>	Page 245
<b>RF MULTI PIN</b>	Page 265
<b>TOOLS</b>	Page 271
<b>ASSEMBLY INSTRUCTIONS</b>	Page 289
<b>SPECIAL PRODUCTS &amp; SERVICES</b>	Page 353
<b>APPENDIX</b>	

e:/quike98/sby.ppt6

# SBY Between-Series Adapters

Adapter Part No.	<b>8001-YF76-02</b>
Connector Config.	<b>SBY-f to 7/16-f</b>
Frequency Range	<b>DC to 7.5 GHz</b>
VSWR	<b>1.06 + 0.005 x f (GHz)</b>

Connector outer conductor is passivated stainless steel.  
Center conductor is gold or/and silver plated.

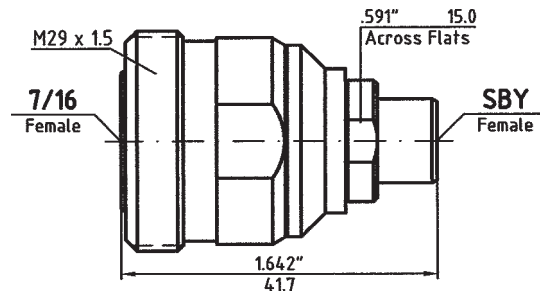

Adapter Part No.	<b>8001-YM76-02</b>
Connector Config.	<b>SBY-m to 7/16-f</b>
Frequency Range	<b>DC to 7.5 GHz</b>
VSWR	<b>1.06 + 0.005 x f (GHz)</b>

Connector outer conductor is passivated stainless steel.  
Center conductor is gold or/and silver plated.

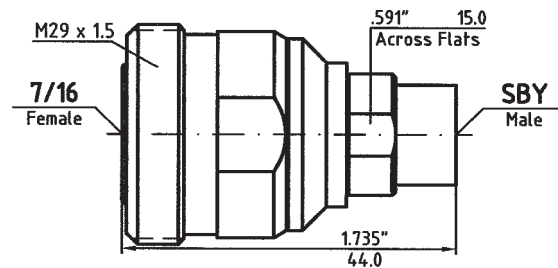

Adapter Part No.	<b>8001-YF75-02</b>
Connector Config.	<b>SBY-f to 7/16-m</b>
Frequency Range	<b>DC to 7.5 GHz</b>
VSWR	<b>1.06 + 0.005 x f (GHz)</b>

Connector outer conductor is passivated stainless steel.  
Center conductor is gold or/and silver plated.

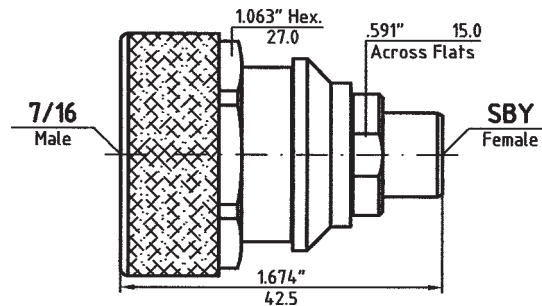

Adapter Part No.	<b>8001-YM75-02</b>
Connector Config.	<b>SBY-m to 7/16-m</b>
Frequency Range	<b>DC to 7.5 GHz</b>
VSWR	<b>1.06 + 0.005 x f (GHz)</b>

Connector outer conductor is passivated stainless steel.  
Center conductor is gold or/and silver plated.

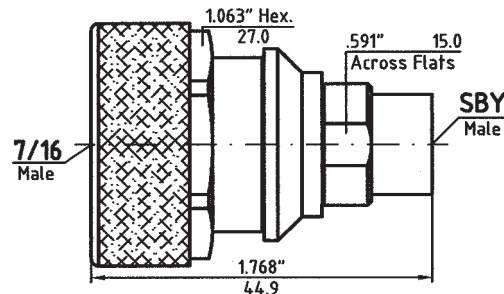

Dimensions shown are inches over millimeters. Standard units have stainless steel finish (last two digits of the P/N are -02). Interfaces are per MIL-C 39012, MIL-C-87104/2, MIL-C-3643, MIL-STD-348, IEC-169-7, IEC-457-2, DIN 47 223, DIN 47 226, DIN 47 298, where applicable. For details please refer to the beginning of this section.

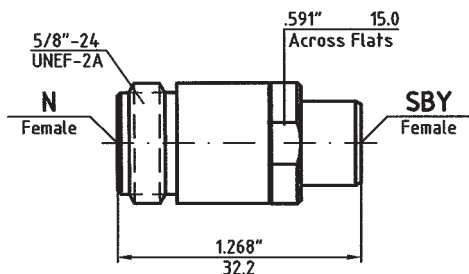

Adapter Part No.	<b>8001-YF61-02</b>
Connector Config.	<b>SBY-f to N-f</b>
Frequency Range	<b>DC to 12.0 GHz</b>
VSWR	<b>1.03 + 0.01 x f (GHz)</b>

Connector outer conductor is passivated stainless steel. Center conductor is gold plated.

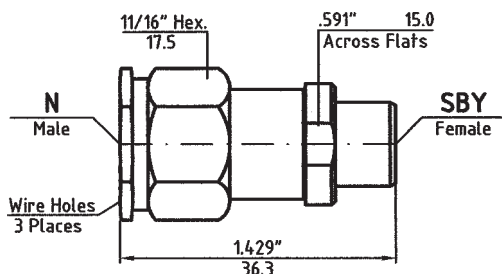

Adapter Part No.	<b>8001-YF51-02</b>
Connector Config.	<b>SBY-f to N-m</b>
Frequency Range	<b>DC to 12.0 GHz</b>
VSWR	<b>1.03 + 0.01 x f (GHz)</b>

Connector outer conductor is passivated stainless steel. Center conductor is gold plated.

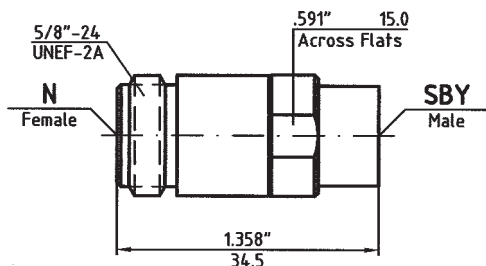

Adapter Part No.	<b>8001-YM61-02</b>
Connector Config.	<b>SBY-m to N-f</b>
Frequency Range	<b>DC to 12.0 GHz</b>
VSWR	<b>1.03 + 0.01 x f (GHz)</b>

Connector outer conductor is passivated stainless steel. Center conductor is gold plated.

Dimensions shown are inches over millimeters. Standard units have stainless steel finish (last two digits of the P/N are -02). Interfaces are per MIL-C 39012, MIL-C-87104/2, MIL-C-3643, MIL-STD-348, IEC-169-7, IEC-457-2, DIN 47 223, DIN 47 226, DIN 47 298, where applicable. For details please refer to the beginning of this section.

# SBY Between-Series Adapters

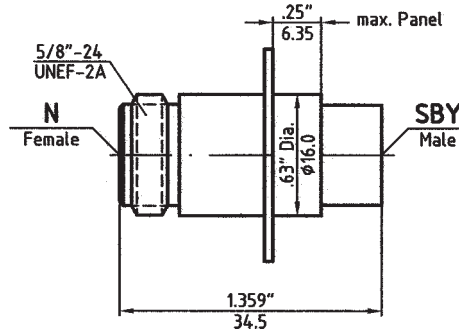
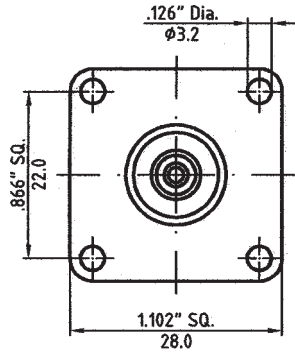

Adapter Part No.	<b>8002-YM61-02</b>
Connector Config.	<b>SBY-m to N-f</b>
Frequency Range	<b>DC to 12.0 GHz</b>
VSWR	<b>1.03 + 0.01 x f (GHz)</b>

Connector outer conductor is passivated stainless steel.  
Center conductor is gold plated.

Adapter Part No.	<b>8001-YM51-02</b>
Connector Config.	<b>SBY-m to N-m</b>
Frequency Range	<b>DC to 12 GHz</b>
VSWR	<b>1.03 + 0.01 x f (GHz)</b>

Connector outer conductor is passivated stainless steel.  
Center conductor is gold plated.

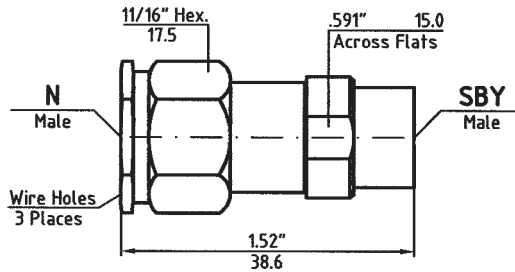

Adapter Part No.	<b>8001-YF21-02</b>
Connector Config.	<b>SBY-f to SMA-f</b>
Frequency Range	<b>DC to 12.0 GHz</b>
VSWR	<b>1.06 + 0.005 x f (GHz)</b>

Connector outer conductor is passivated stainless steel.  
Center conductor is gold plated.

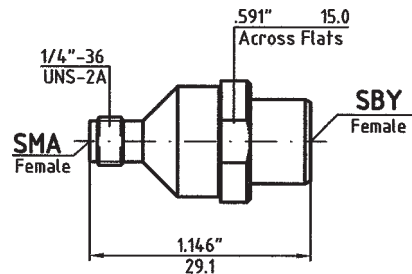

Dimensions shown are inches over millimeters. Standard units have stainless steel finish (last two digits of the P/N are -02). Interfaces are per MIL-C 39012, MIL-C-87104/2, MIL-C-3643, MIL-STD-348, IEC-169-7, IEC-457-2, DIN 47 223, DIN 47 226, DIN 47 298, where applicable. For details please refer to the beginning of this section.

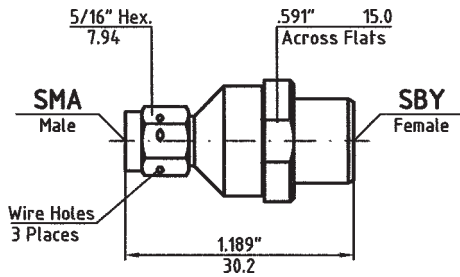

Adapter Part No.	<b>8001-YF11-02</b>
Connector Config.	<b>SBY-f to SMA-m</b>
Frequency Range	<b>DC to 12.0 GHz</b>
VSWR	<b>1.06 + 0.005 x f (GHz)</b>

Connector outer conductor is passivated stainless steel. Center conductor is gold plated.

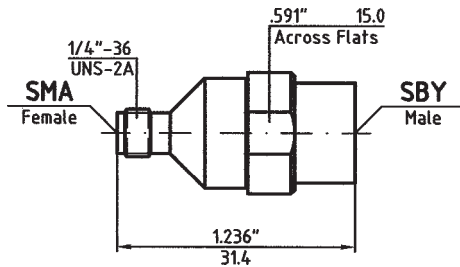

Adapter Part No.	<b>8001-YM21-02</b>
Connector Config.	<b>SBY-m to SMA-f</b>
Frequency Range	<b>DC to 12.0 GHz</b>
VSWR	<b>1.06 + 0.005 x f (GHz)</b>

Connector outer conductor is passivated stainless steel. Center conductor is gold plated.

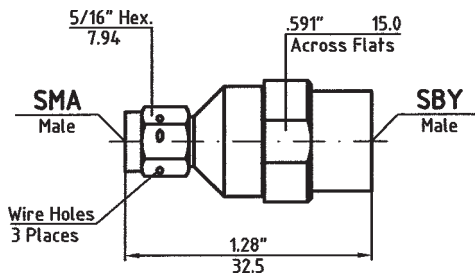

Adapter Part No.	<b>8001-YM11-02</b>
Connector Config.	<b>SBY-m to SMA-m</b>
Frequency Range	<b>DC to 12.0 GHz</b>
VSWR	<b>1.06 + 0.005 x f (GHz)</b>

Connector outer conductor is passivated stainless steel. Center conductor is gold plated.

Dimensions shown are inches over millimeters. Standard units have stainless steel finish (last two digits of the P/N are -02). Interfaces are per MIL-C 39012, MIL-C-87104/2, MIL-C-3643, MIL-STD-348, IEC-169-7, IEC-457-2, DIN 47 223, DIN 47 226, DIN 47 298, where applicable. For details please refer to the beginning of this section.

e:/quike98/sby.ppt6

# SBY Float Mount Adapters

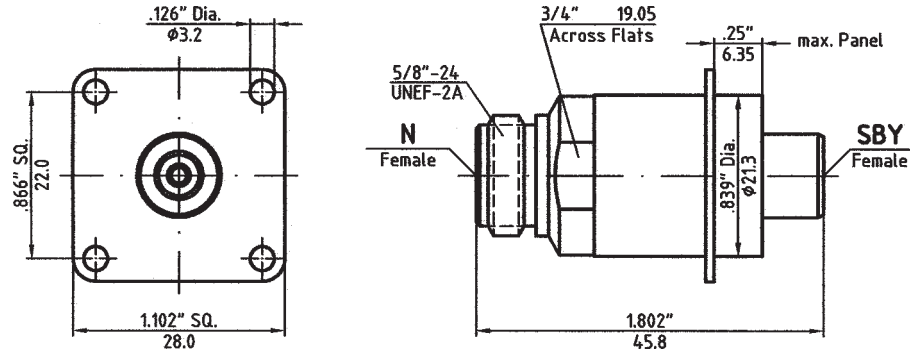

Adapter Part No.	<b>8002-YF61-02</b>
Connector Config.	<b>SBY-f to N-f</b>
Frequency Range	<b>DC to 12.0 GHz</b>
VSWR	<b>1.03 + 0.01 x f (GHz)</b>

Connector outer conductor is passivated stainless steel.  
Center conductor is gold plated.

Dimensions shown are inches over millimeters. Standard units have stainless steel finish (last two digits of the P/N are -02). Interfaces are per MIL-C 39012, MIL-C-87104/2, MIL-C-3643, MIL-STD-348, IEC-169-7, IEC-457-2, DIN 47 223, DIN 47 226, DIN 47 298, where applicable. For details please refer to the beginning of this section.