

TNC Specifications to MIL-C-39012



The specifications below are general specifications for all TNC connectors. Specific Data for VSWR, Insertion Loss, R.F. leakage, etc., are available from the factory upon request. Specifications in the following table are recommended for any procurement documents or drawings. In the event of any conflict between these specifications and General Specifications MIL-C-39012, these specifications shall govern. The paragraph numbers refer to the associated requirement paragraphs of MIL-C-39012/C. These specifications are subject to change according to the latest revision.

REQUIREMENT	REQUIREMENT PARAGRAPH	GENERAL SPECIFICATIONS
GENERAL		
Standard Materials	3.3	STEEL corrosion resistant 1.4305 per DIN 17440 (QQ-S-764, class 303 or ASTM-A-582-80), ALUMINUM AlMg4.5Mn per DIN 1725, AlMgSi0.5 per DIN 1725, AlMgSi1 per DIN 1725 (6061-T6 per QQ-A-225/8). BRASS CuZn39Pb3 per DIN 17660 (QQ-B-626, half hard). COPPER BERYLLIUM 33-25 CuBe2Pb H per DIN 17666 (QQ-C-530). TFE Fluorocarbon per DIN 52900 (MIL-P-19468 and L-P403). SILICONE RUBBER per DIN 3771 (MIL-R-5847 and ZZ-R-765, Class II B,) Grade 50 - 75. BORRIUM NITRITE Dielectric for high power applications per inhouse specification.
Finish for	COPPER BERYLLIUM 3.3.1	Center Contacts shall be gold plated to a minimum thickness of .00005 inch (1.27 µm) in accordance with MIL-G-45204, Type II, Grade C.
	STAINLESS STEEL	shall be passivated per QQ-P-35.
	ALUMINUM	Conductive Parts shall have an iridited finish per MIL-C-5541.
	BRASS	Other parts, such as Coupling Nuts and Back-Bodies shall be anodized per MIL-A-8625.
	VARIOUS	.00003 inch (0.8 µm) min. gold plating per MIL-G-45204, or nicle plating per QQ-N-290, as specified.
		Imoloy .0001 inch (2.5 µm) min. plating, consisting of 55% Copper / 20% Zinc / 25% Tin (on special request).
Design	3.4	The design shall be such that the outline dimensions in this catalog are met. In addition, the assembled connector shall meet the interface dimensions.
ELECTRICAL		
Frequency Range	3.5.1.1	DC - 11.0 GHz min.
Insulation Resistance	3.11*	The insulation resistance shall not be less than 5,000 megohms.
Voltage Standing Wave Ratio (VSWR)	3.5.1.2	1.03 + .005 * f (GHz)
Contact Resistance	3.16*	The center contact resistance drop shall not exceed 1.5 milliohms and the outer contact resistance drop shall not exceed 2.0 milliohms.
Dielectric Withstanding Voltage	3.17*	The magnitude of the test voltage shall be 1,500 volts rms at sea level.
High Potential Test Voltage	3.23	The high potential test voltage is 1,500 volts rms. Leakage is not applicable.
RF Leakage	3.5.1.8	-(90 - f (GHz)) dB
Insertion Loss	3.5.1.3	(.05 SQT(f(GHz))) dB
MECHANICAL		
Connector Durability	3.15*	The connector is to be tested and its mating connector shall be subjected to 500 insertion and withdrawal cycles at 12 cycles per minute max. The connector shall show no evidence of mechanical failure and the connector shall meet the mating characteristic requirements.
Cable Retention Force	3.24*	90 pounds (400 N) min.
Coupling Nut Retention Force	3.25*	Not applicable for Female connectors. For male connectors, the axial force is 100 lbs (445 N) max.. The torque is 30 inch-pounds (3.4 Nm) max.
Force to Engage and Disengage Longitudinal Force max.	3.5.1*	The torque required to engage and disengage shall not exceed 2-4 inch-pounds (0.452-0.678 Nm). Longitudinal force is not applicable.
Mating Characteristics	3.7*	See interface dimensions shown on next page. Applicable to Females only: oversize pin .055 inch (1.4 mm) max. dia., .080 inch (2.03 mm) deep; insertion force 2 lbs. (8.9 N) max. with .054 inch (1.37 mm) min. dia. pin; withdrawal force 2.00 oz (.556 N) min. with .052 inch (1.32 mm) max. dia. pin.
Recommended Mating Torque		12 - 15 inch-pounds (1.4 - 1.7 Nm)
ENVIRONMENTAL		
Corrosion (Salt Spray)	3.13*	Specification MIL-STD-202, Method 101, Test Condition B. The salt solution shall be 5%.
Vibration	3.18*	Specification MIL-STD-202, Method 204, Test Condition B.
Shock	3.19*	Specification MIL-STD-202, Method 213, Test Condition I.
Thermal Shock	3.20*	Specification MIL-STD-202, Method 107, Test Condition B, except high temperature shall be + 200°C.
Moisture Resistance	3.21*	Specification MIL-STD-202, Method 106. Step 7b (vibration) shall be omitted. Insulation resistance shall be 200 megohms min. within 5 minutes of removal from humidity.
Corona Level	3.5.1.4	The connector shall not exhibit breakdown (corona) when the applied voltage is 375 volts rms and the altitude is 0 feet.

TNC Specifications to MIL-C-87104/2



The specifications below are general specifications for all TNC connectors. Specific Data for VSWR, Insertion Loss, R.F. leakage, etc., are available from the factory upon request. Specifications in the following table are recommended for any procurement documents or drawings. In the event of any conflict between these specifications and General Specifications MIL-C-87104/2, these specifications shall govern. The paragraph numbers refer to the associated requirement paragraphs of MIL-C-87104/2. These specifications are subject to change according to the latest revision.

REQUIREMENT	REQUIREMENT PARAGRAPH	GENERAL SPECIFICATIONS
GENERAL		
Standard Materials	3.3	STEEL corrosion resistant 1.4305 per DIN 17440 (QQ-S-764, class 303 or ASTM-A-582-80). ALUMINUM AlMg4.5Mn per DIN 1725, AlMgSi0.5 per DIN 1725, AlMgSi1 per DIN 1725 (6061-T6 per QQ-A-225/8). BRASS CuZn39Pb3 per DIN 17660 (QQ-B-626, half hard). COPPER BERYLLIUM 33-25 CuBe2Pb H per DIN 17666 (QQ-C-530). TFE Fluorocarbon per DIN 52900 (MIL-P-19468 and L-P403). SILICONE RUBBER per DIN 3771 (MIL-R-5847 and ZZ-R-765, Class II B,) Grade 50 - 75. BORRIUM NITRITE Dielectric for high power applications per inhouse specification.
Finish for	COPPER BERYLLIUM 3.3.1	Center Contacts shall be gold plated to a minimum thickness of .00005 inch (1.27 μm) in accordance with MIL-G-45204, Type II, Grade C.
	STAINLESS STEEL	shall be passivated per QQ-P-35.
	ALUMINUM	Conductive Parts shall have an iridited finish per MIL-C-5541.
	BRASS	Other parts, such as Coupling Nuts and Back-Bodies shall be anodized per MIL-A-8625.
	VARIOUS	.00003 inch (0.8 μm) min. gold plating per MIL-G-45204, or nicle plating per QQ-N-290, as specified.
		Imoloy .0001 inch (2.5 μm) min. plating, consisting of 55% Copper / 20% Zinc / 25% Tin (on special request).
Design	3.4	The design shall be such that the outline dimensions in this catalog are met. In addition, the assembled connector shall meet the interface dimensions.
ELECTRICAL		
Frequency Range	3.5.1.1	DC - 18.0 GHz min.
Insulation Resistance	3.11*	The insulation resistance shall not be less than 5,000 megohms.
Voltage Standing Wave Ratio (VSWR)	3.5.1.2	1.03 + .005 * f (GHz)
Contact Resistance	3.16*	The center contact resistance drop shall not exceed 1.5 milliohms and the outer contact resistance drop shall not exceed 2.0 milliohms.
Dielectric Withstanding Voltage	3.17*	The magnitude of the test voltage shall be 1,500 volts rms at sea level.
High Potential Test Voltage	3.23	The high potential test voltage is 2,000 volts rms. Leakage is not applicable.
RF Leakage	3.5.1.8	-(90 - f (GHz)) dB
Insertion Loss	3.5.1.3	(.05 SQT(f(GHz))) dB
MECHANICAL		
Connector Durability	3.15*	The connector is to be tested and its mating connector shall be subjected to 500 insertion and withdrawal cycles at 12 cycles per minute max. The connector shall show no evidence of mechanical failure and the connector shall meet the mating characteristic requirements.
Cable Retention Force	3.24*	90 pounds (400 N) min.
Coupling Nut Retention Force	3.25*	Not applicable for Female connectors. For male connectors, the axial force is 100 lbs (445 N) max.. The torque is 30 inch-pounds (3.4 Nm) max.
Force to Engage and Disengage Longitudinal Force max.	3.5.1*	The torque required to engage and disengage shall not exceed 2-4 inch-pounds (0.452-0.678 Nm). Longitudinal force is not applicable.
Mating Characteristics	3.7*	See interface dimensions shown on next page. Applicable to Females only: oversize pin .055 inch (1.4 mm) max. dia.,.080 inch (2.03 mm) deep; insertion force 2 lbs. (8.9 N) max. with .054 inch (1.37 mm) min. dia. pin; withdrawal force 2.00 oz (.556 N) min. with .052 inch (1.32 mm) max. dia. pin.
Recommended Mating Torque		12 - 15 inch-pounds (1.4 - 1.7 Nm)
ENVIRONMENTAL		
Corrosion (Salt Spray)	3.13*	Specification MIL-STD-202, Method 101, Test Condition B. The salt solution shall be 5%.
Vibration	3.18*	Specification MIL-STD-202, Method 204, Test Condition B.
Shock	3.19*	Specification MIL-STD-202, Method 213, Test Condition I.
Thermal Shock	3.20*	Specification MIL-STD-202, Method 107, Test Condition B, except high temperature shall be + 200°C.
Moisture Resistance	3.21*	Specification MIL-STD-202, Method 106. Step 7b (vibration) shall be omitted. Insulation resistance shall be 200 megohms min. within 5 minutes of removal from humidity.
Corona Level	3.5.1.4	The connector shall not exhibit breakdown (corona) when the applied voltage is 375 volts rms and the altitude is 0 feet.

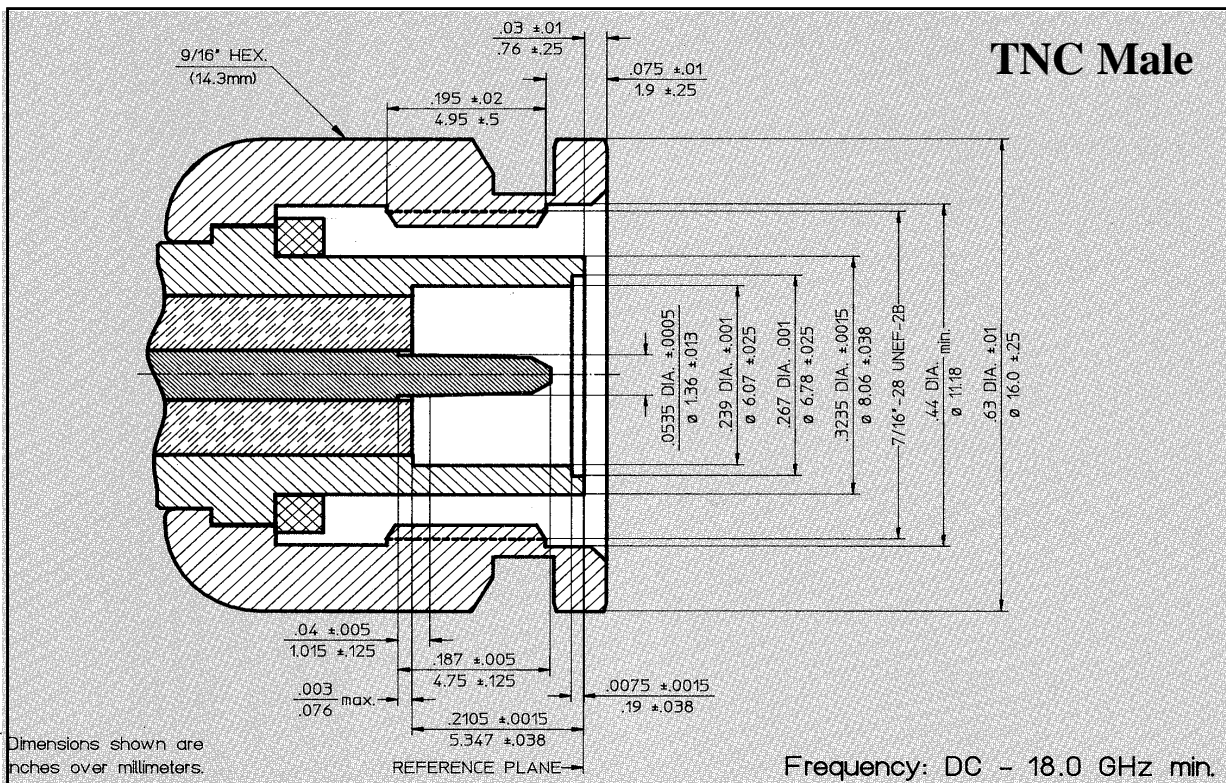
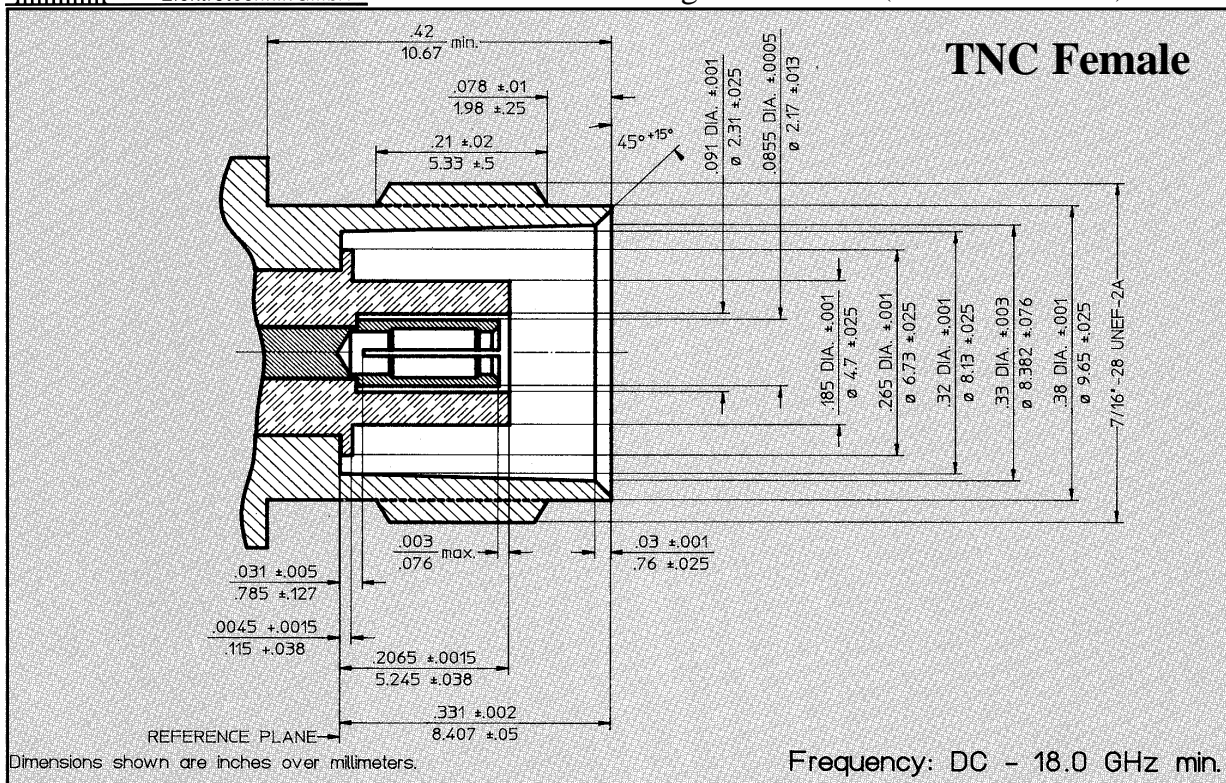

In-Series Adapters to Type TNC

Part - No.	8001-4141-02
Connectors	TNC-F to TNC-F
Frequency	DC - 18.0 GHz
VSWR max.	1.06 + 0.005 x f(GHz)

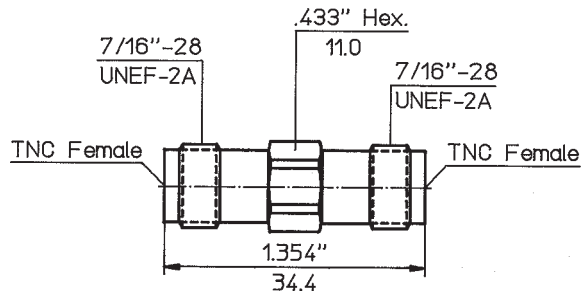

TNC-Interfaces as per MIL-C-87104/2

Part - No.	8002-4141-02
Connectors	TNC-F to TNC-F
Frequency	DC - 18.0 GHz
VSWR max.	1.06 + 0.005 x f(GHz)

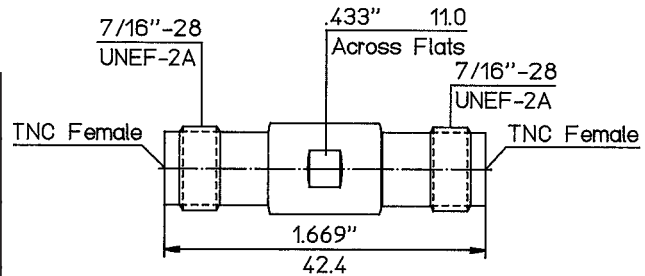

TNC-Interfaces as per MIL-C-87104/2

Part - No.	8003-4141-02
Connectors	TNC-F to TNC-F
Frequency	DC - 18.0 GHz
VSWR max.	1.06 + 0.005 x f(GHz)

4-Hole Flange

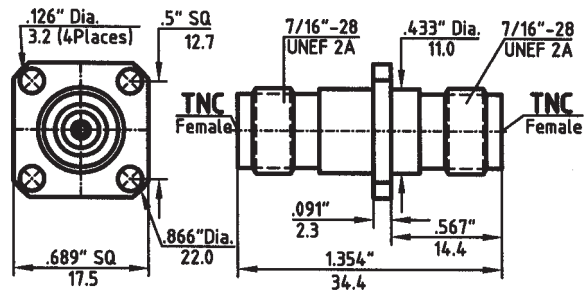

TNC-Interfaces as per MIL-C-87104/2

Part - No.	8004-4141-02
Connectors	TNC-F to TNC-F
Frequency	DC - 18.0 GHz
VSWR max.	1.06 + 0.005 x f(GHz)

Bulkhead Feedthrough

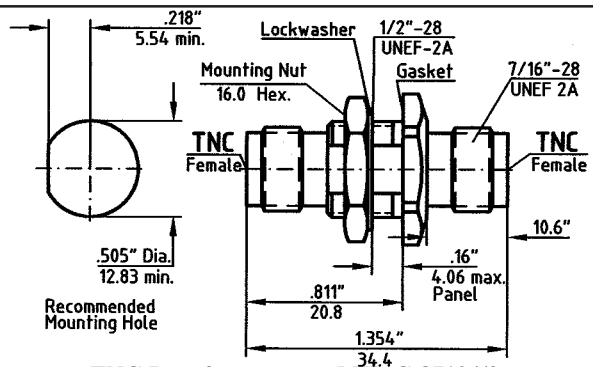

TNC-Interfaces as per MIL-C-87104/2

Dimensions shown are inches over millimeters. Standard units have stainless steel finish (last two digits of the P/N are -02). Interfaces are per MIL-C 39012, MIL-C-87104/2, MIL-C-3643, MIL-STD-348, IEC-169-7, IEC-457-2, DIN 47 223, DIN 47 226, DIN 47 298, where applicable. For details please refer to the beginning of this section.

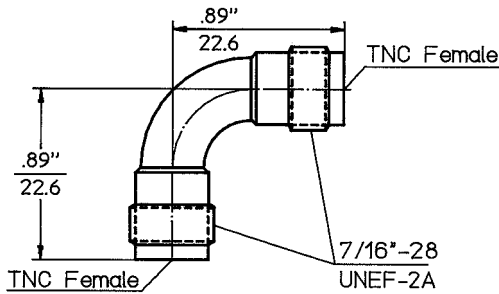

TNC-Interfaces as per MIL-C-87104/2

Radius Right Angle

Part - No.	8091-4141-02
Connectors	TNC-F to TNC-F
Frequency	DC - 18.0 GHz
VSWR max.	1.06 + 0.005 x f (GHz)

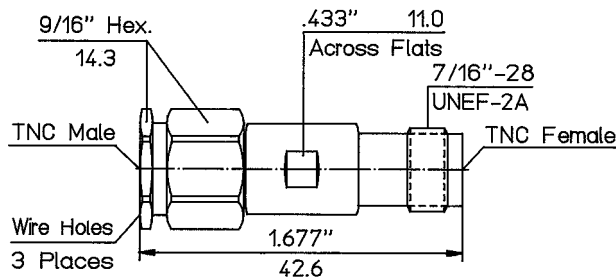

TNC-Interfaces as per MIL-C-87104/2

Part - No.	8001-3141-02
Connectors	TNC-M to TNC-F
Frequency	DC - 18.0 GHz
VSWR max.	1.06 + 0.005 x f (GHz)

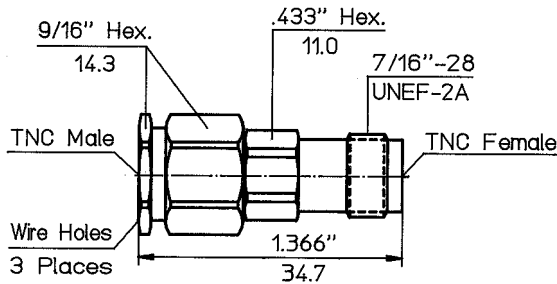

TNC-Interfaces as per MIL-C-87104/2

Part - No.	8002-3141-02
Connectors	TNC-M to TNC-F
Frequency	DC - 18.0 GHz
VSWR max.	1.06 + 0.005 x f (GHz)

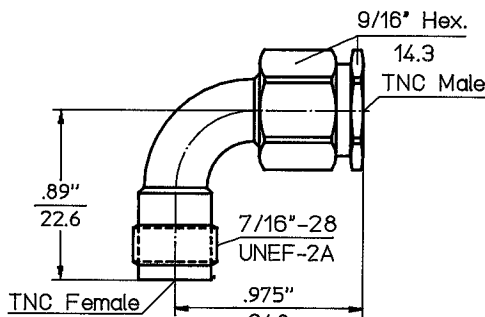

TNC-Interfaces as per MIL-C-87104/2

Radius Right Angle

Part - No.	8091-3141-02
Connectors	TNC-M to TNC-F
Frequency	DC - 18.0 GHz
VSWR max.	1.06 + 0.005 x f (GHz)

Dimensions shown are inches over millimeters. Standard units have stainless steel finish (last two digits of the P/N are -02). Interfaces are per MIL-C 39012, MIL-C-87104/2, MIL-C-3643, MIL-STD-348, IEC-169-7, IEC-457-2, DIN 47 223, DIN 47 226, DIN 47 298, where applicable. For details please refer to the beginning of this section.

In-Series Adapters to Type TNC

Outer Conductor is stainless steel gold plated, coupling nuts are stainless steel passivated.

Part - No.	8095-3141-02
Connectors	TNC-M to TNC-F
Frequency	DC - 10.0 GHz
VSWR max.	1.20 : 1

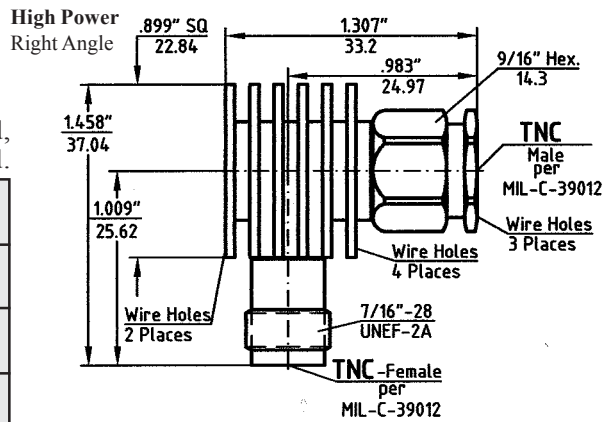

Part - No.	8001-3131-02
Connectors	TNC-M to TNC-M
Frequency	DC - 18.0 GHz
VSWR max.	1.06 + 0.005 x f (GHz)

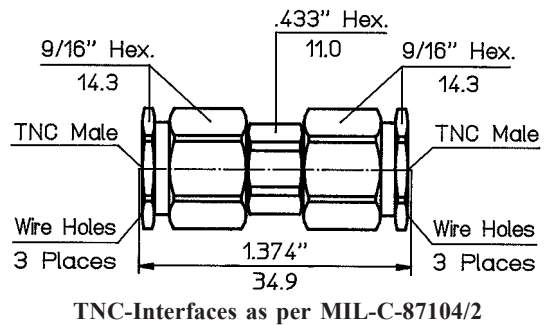

Outer Conductor is stainless steel gold plated, coupling nuts are stainless steel passivated.

Part - No.	8050-3131-02
Connectors	TNC-M to TNC-M
Frequency	DC - 12.4 GHz
VSWR max.	1.15 : 1

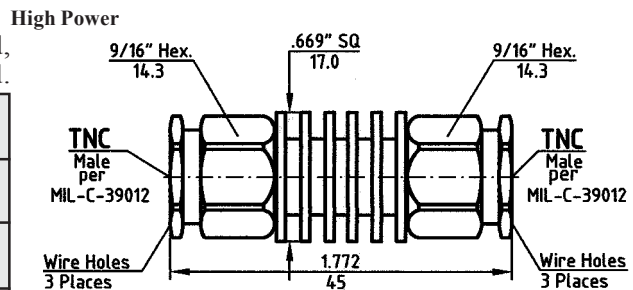

Part - No.	8091-3131-02
Connectors	TNC-M to TNC-M
Frequency	DC - 18.0 GHz
VSWR max.	1.06 + 0.005 x f (GHz)

Radius Right Angle

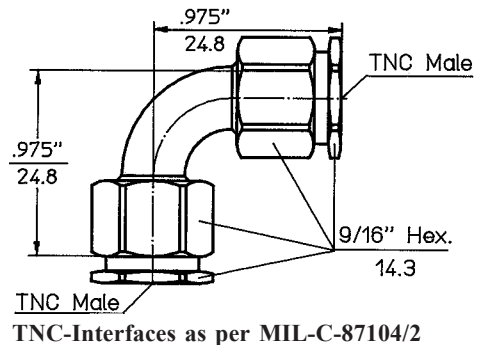

Dimensions shown are inches over millimeters. Standard units have stainless steel finish (last two digits of the P/N are -02). Interfaces are per MIL-C 39012, MIL-C-87104/2, MIL-C-3643, MIL-STD-348, IEC-169-7, IEC-457-2, DIN 47 223, DIN 47 226, DIN 47 298, where applicable. For details please refer to the beginning of this section.