

# BMA Specifications



The specifications below are general specifications for all BMA connectors. Specific Data for VSWR, Insertion loss, R.F. leakage etc., are available from the factory upon request. Specifications in the following table are recommended for any procurement documents or drawings. In the event of any conflict between these specifications and other documentation, these specifications shall govern. These specifications are subject to change according to the latest revision.

REQUIREMENT	GENERAL SPECIFICATIONS
<b>GENERAL</b>	
Standard Materials	STEEL corrosion resistant 1.4305 per DIN 17440 (QQ-S-764, class 303 or ASTM-A-582-80). ALUMINUM AlMg4.5Mn per DIN 1725, AlMgSi0.5 per DIN 1725, AlMgSi1 per DIN 1725 (6061-T6 per QQ-A-225/8). BRASS CuZn39Pb3 per DIN 17660 (QQ-B-626, half hard). COPPER BERYLLIUM 33-25 CuBe2Pb H per DIN 17666 (QQ-C-530). TFE Fluorocarbon per DIN 52900 (MIL-P-19468 and L-P403). SILICONE RUBBER per DIN 3771 (MIL-R-5847 and ZZ-R-765, Class II B,) Grade 50 - 75. BORRIUM NITRITE Dielectric for high power applications per inhouse specification.
Finish for COPPER BERYLLIUM STAINLESS STEEL ALUMINUM BRASS VARIOUS	Center Contacts shall be gold plated to a minimum thickness of .00005 inch (1.27 µm) in accordance with MIL-G-45204, Type II, Grade C. shall be passivated per QQ-P-35. Conductive Parts shall have an iridited finish per MIL-C-5541. Other parts, such as Coupling Nuts and Back-Bodies shall be anodized per MIL-A-8625. .00003 inch (0.8 µm) min. gold plating per MIL-G-45204, or nicle plating per QQ-N-290, as specified. Imoloy .0001 inch (2.5 µm) min. plating, consisting of 55% Copper / 20% Zinc / 25% Tin (on special request).
Design	The design shall be such that the outline dimensions in this catalog are met. In addition, the assembled connector shall meet the interface dimensions.
<b>ELECTRICAL</b>	
Frequency Range	DC - 22.0 GHz min.
Insulation Resistance	The insulation resistance shall not be less than 5.000 megohms.
Voltage Standing Wave Ratio (VSWR)	1.05 + 0.009 * f (GHz)
Contact Resistance	The center contact resistance drop shall not exceed 2.0 milliohms and the outer contact resistance drop shall not exceed 2.0 milliohms.
Dielectric Withstanding Voltage	The magnitude of the test voltage shall be 1.000 volts rms at sea level.
RF High Potential Withstanding Voltage	The RF high potential withstanding voltage is 1.000 volts rms at 5 MHz. Leakage is not applicable.
RF Leakage	RF Leakage is not applicable
Insertion Loss	(.05 SQT(f(GHz))) dB
<b>MECHANICAL</b>	
Connector Durability	The connector is to be tested and its mating connector shall be subjected to 500 insertion min. Withdrawal cycles / minute are not applicable. The connector shall show no evidence of mechanical failure and the connector shall meet the mating characteristic requirements.
Cable Retention Force	6 pounds (26.7 N) min.
Coupling Nut Retention Force	Not applicable for Female connectors. For male connectors, the axial force is 6 lbs (26,7 N) max.
Force to Engage and Disengage	The torque required to engage shall not exceed 3 lbs. (13.4 N). The disengage force shall not exceed 1.5 lbs. (6.7 N) max.
Mating Characteristics	See interface dimensions shown on next page. Applicable to Females only: oversize pin .0373 inch (0.09 mm) max. dia., .045inch (1.15 mm) deep; insertion force max. with min. dia. pin is not applicable; withdrawal force 1.0 oz (2.8 N) min. with .0355 inch (0.9 mm) max. dia. pin.
Recommended Mating Torque	Recommended Mating Torque is not applicable.
<b>ENVIRONMENTAL</b>	
Corrosion (Salt Spray)	Specification MIL-STD-202, Method 101, Test Condition B. The salt solution shall be 5%.
Vibration	Specification MIL-STD-202, Method 204, Test Condition D.
Shock	Specification MIL-STD-202, Method 213, Test Condition I.
Thermal Shock	Specification MIL-STD-202, Method 107, Test Condition B, except high temperature shall be + 200°C.
Moisture Resistance	Specification MIL-STD-202, Method 106. Step 7b (vibration) shall be omitted. Insulation resistance shall be 200 megohms min. within 5 minutes of removal from humidity.
Corona Level	The connector shall not exhibit breakdown (corona) when the applied voltage is 335 volts rms and the altitude is 70.000 feet.

**BMA Female**

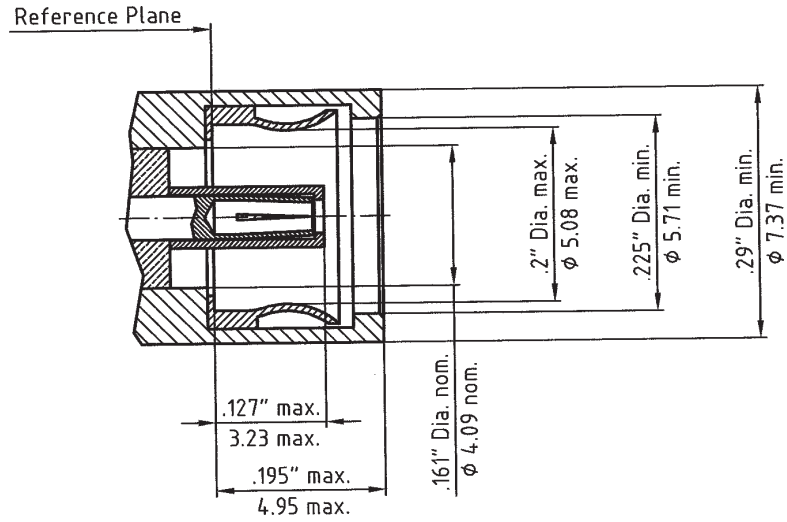

Frequency: DC - 22.0 GHz min.

**BMA Male**

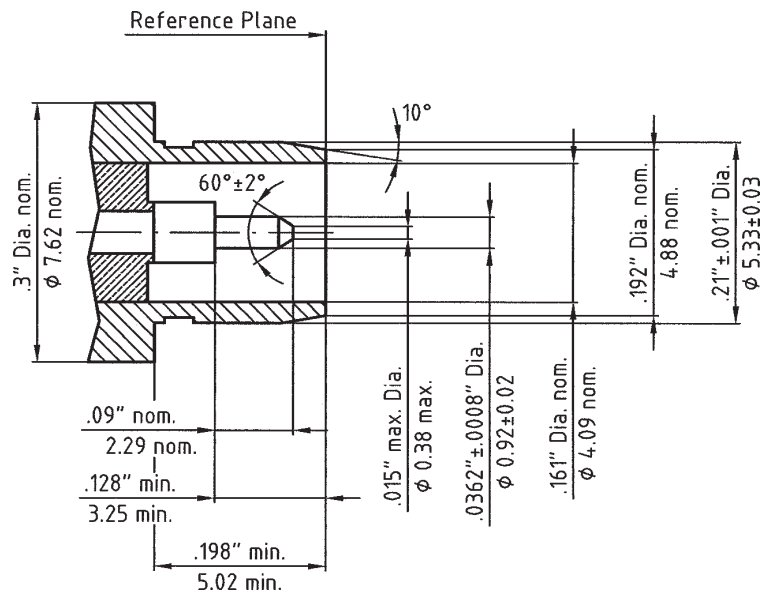

Frequency: DC - 22.0 GHz min.

# Between-Series Adapters to Type BMA

<b>Part - No.</b>	<b>8001-BW21-02</b>
Connectors	<b>BMA-F to SMA-F</b>
Frequency	DC - 18.0 GHz
VSWR max.	1.06 + 0.005 x f (GHz)

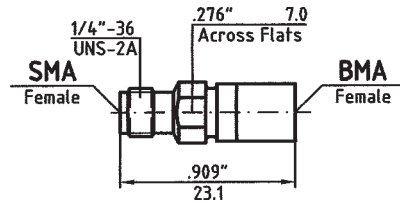

<b>Part - No.</b>	<b>8001-BW11-02</b>
Connectors	<b>BMA-F to SMA-M</b>
Frequency	DC - 18.0 GHz
VSWR max.	1.06 + 0.005 x f (GHz)

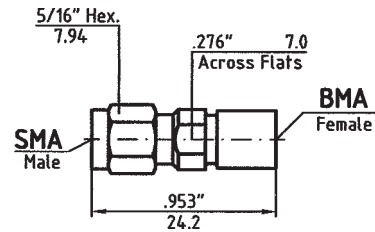

<b>Part - No.</b>	<b>8001-BM21-02</b>
Connectors	<b>BMA-M to SMA-F</b>
Frequency	DC - 18.0 GHz
VSWR max.	1.06 + 0.005 x f (GHz)

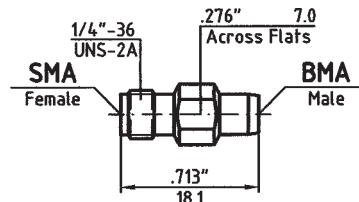

<b>Part - No.</b>	<b>8001-BM11-02</b>
Connectors	<b>BMA-M to SMA-M</b>
Frequency	DC - 18.0 GHz
VSWR max.	1.06 + 0.005 x f (GHz)

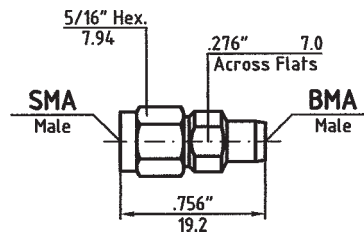

Dimensions shown are inches over millimeters. Standard units have stainless steel finish (last two digits of the P/N are -02). Interfaces are per MIL-C 39012, MIL-C-87104/2, MIL-C-3643, MIL-STD-348, IEC-169-7, IEC-457-2, DIN 47 223, DIN 47 226, DIN 47 298, where applicable. For details please refer to the beginning of this section.